



HARTMETALL

**BIMHKE**



ΚΑΤΑΛΟΓΟΣ ΕΡΓΑΛΕΙΩΝ  
CUTTING TOOLS CATALOGUE



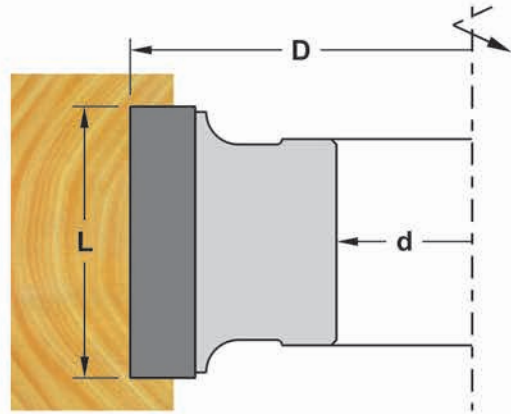

Part No	D	L	Z
2101-084	125	8	4
2101-104	125	10	4
2101-124	125	12	4
2101-144	125	14	4
2101-164	125	16	4
2101-184	125	18	4
2101-204	125	20	4
2101-224	125	22	4
2101-304	125	30	4
2101-404	125	40	4
2101-504	125	50	4
2101-604	125	60	4
2101-704	125	70	4
2101-804	125	80	4
2101-904	125	90	4
2101-994	125	100	4

Part No	D	L	Z
2101-086	125	8	6
2101-106	125	10	6
2101-126	125	12	6
2101-146	125	14	6
2101-166	125	16	6
2101-186	125	18	6
2101-206	125	20	6
2101-226	125	22	6
2101-306	125	30	6
2101-406	125	40	6
2101-506	125	50	6
2101-606	125	60	6
2101-706	125	70	6
2101-806	125	80	6
2101-906	125	90	6
2101-996	125	100	6

**HM**

**d50**

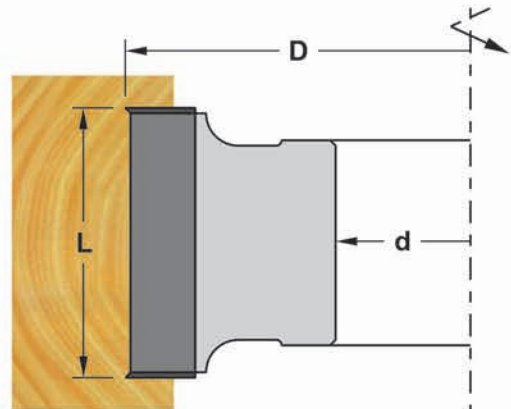

Part No	D	L	Z	V
2102-050	125	50	4	4



V: προχάραξη / spur

**HM**

**d50**

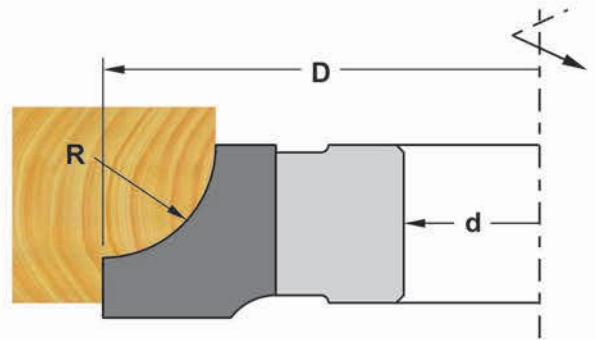

Part No	D	R	Z
2103-005	125	5	4
2103-008	125	8	4
2103-010	125	10	4
2103-015	130	15	4
2103-020	140	20	4
● 2103-0225	150	22.5	4
2103-025	150	25	4
2103-030	160	30	4
● 2103-032.5	165	32.5	4
2103-035	170	35	4
2103-040	180	40	4
2103-045	190	45	4
2103-050	200	50	4

● Κατόπιν παραγγελίας / special numbers

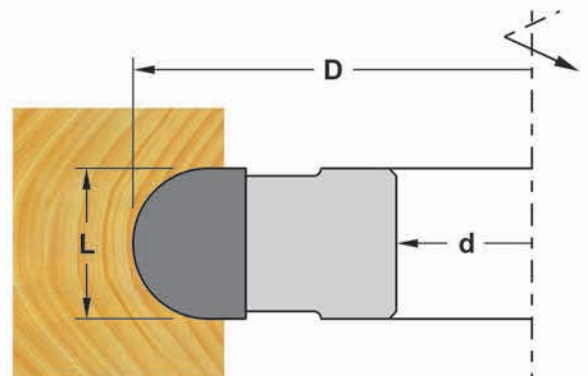
**HM**
**d50**

Part No	D	L	Z
2104-008	125	8	4
2104-010	125	10	4
2104-015	125	15	4
2104-020	125	20	4
2104-025	125	25	4
2104-030	130	30	4
2104-035	135	35	4
2104-040	140	40	4
2104-045	150	45	4
2104-050	150	50	4
2104-060	160	60	4

**HM**
**d50**



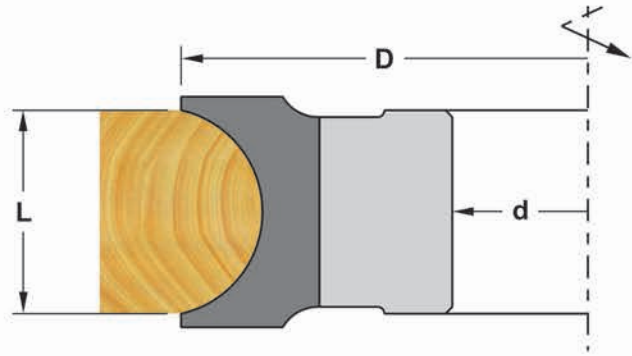
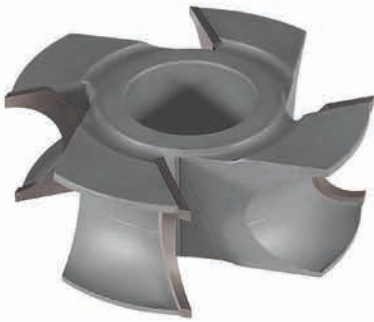

Part No	D	L	Z
2105-010	120	10	4
2105-015	120	15	4
2105-020	125	20	4
2105-025	125	25	4
2105-030	130	30	4
2105-035	135	35	4
2105-040	140	40	4
2105-045	150	45	4
2105-050	150	50	4
2105-060	160	60	4

**HM**

**d50**

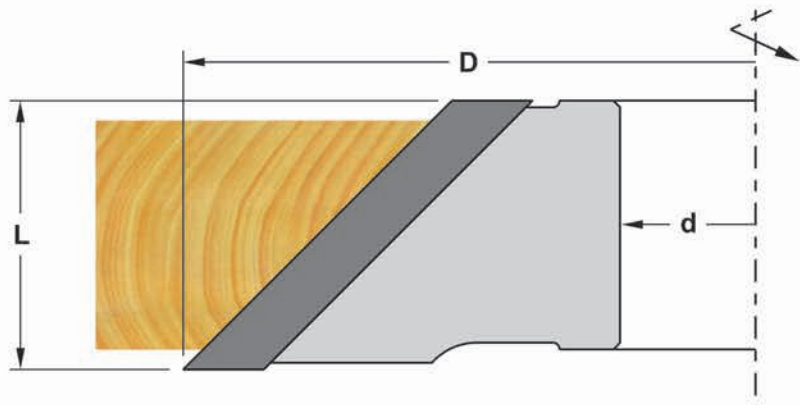

Part No	D	L	Z
2106-020	130	20	4
2106-030	150	30	4
2106-031	150	30/22.5°	4
2106-040	180	40	4
2106-050	200	50	4

**HM**

**d50**

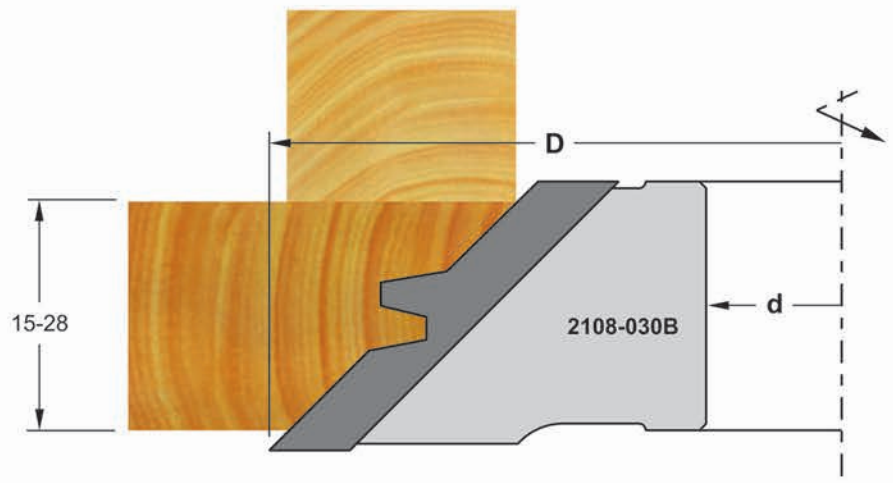
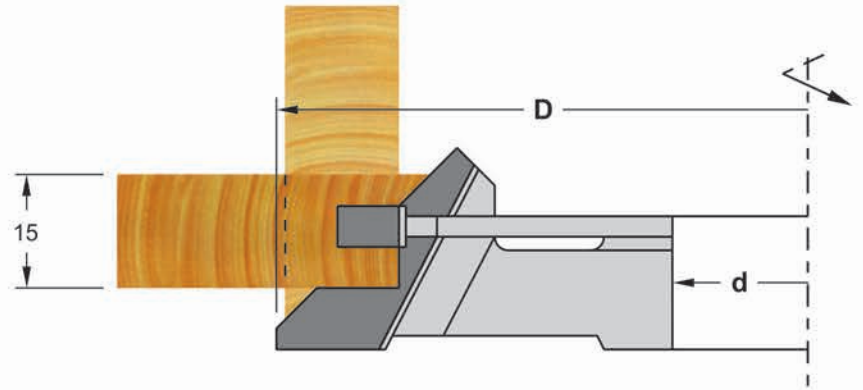
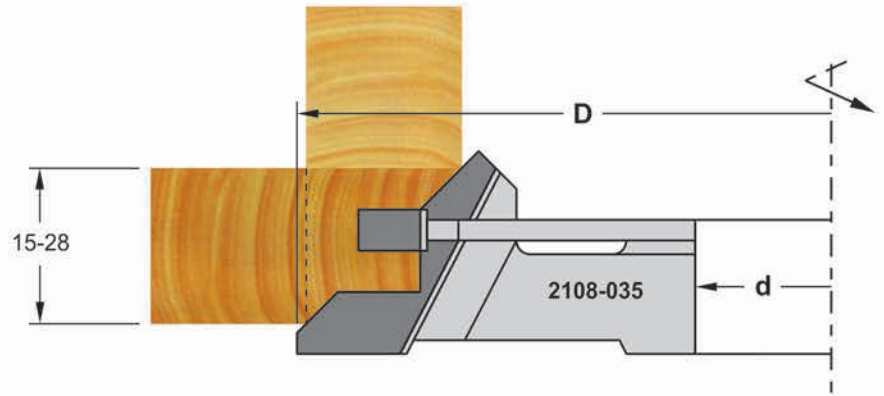

Part No	D	Z
2108-035	160	3
2108-030B	165	4

HM d50

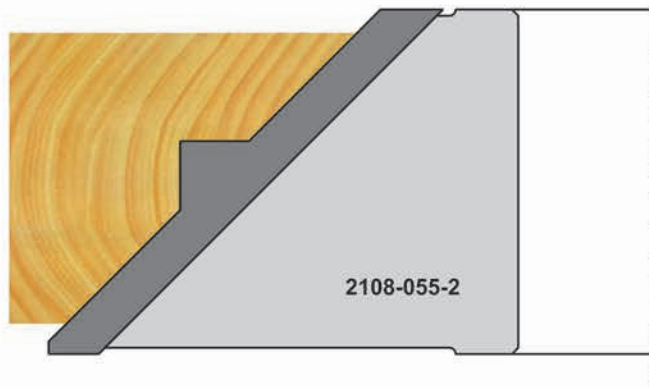
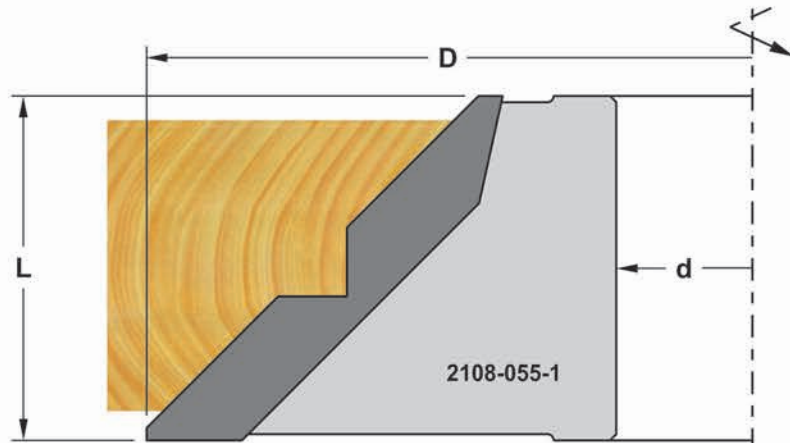

	D	L	Z
2108-055-1	200	35/55	4
2108-055-2	200	35/55	4

**HM d50**

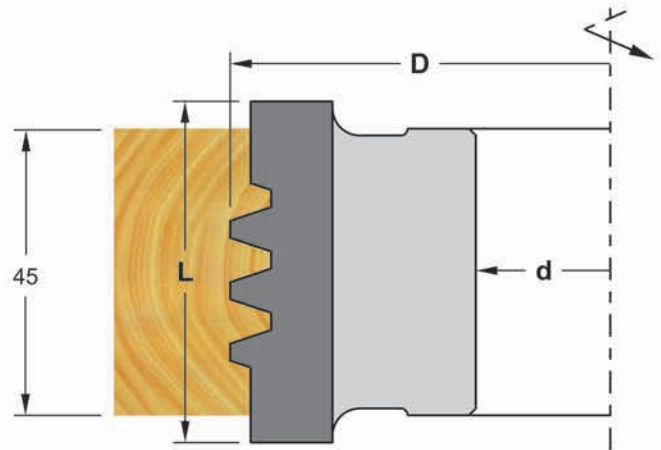

Part No	D	L	Z
2109-050	125	50	4

**HM** **d50**

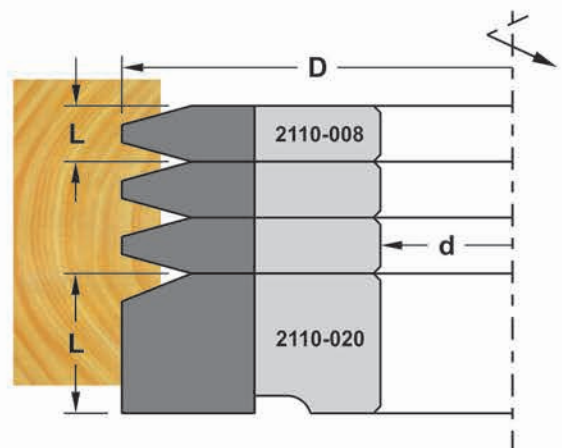

Part No	D	L	Z
2110-008	125	8	4
2110-020	125	20	4

**HM** **d50**



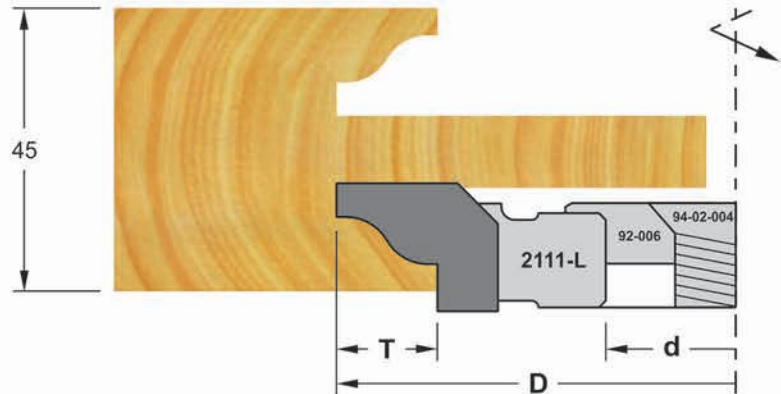

η τιμή της φρέζας δεν περιλαμβάνει βίδα-καπελάκι-κλειδί /  
spanner, screw and reducing bushing have extra price

Part No	D	T	Z
2111-015L	130	15	4
2111-017L	130	17	4
2111-K	ΚΛΕΙΔΙ / spanner		
92-006	ΚΑΠΕΛΑΚΙ / reducing bushing		
B-02-004	ΒΙΔΑ ALLEN / allen screw		

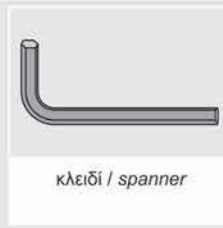
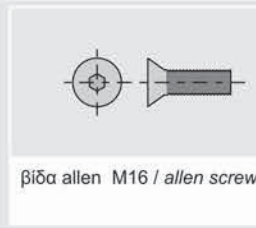

**HM**  
**d50**

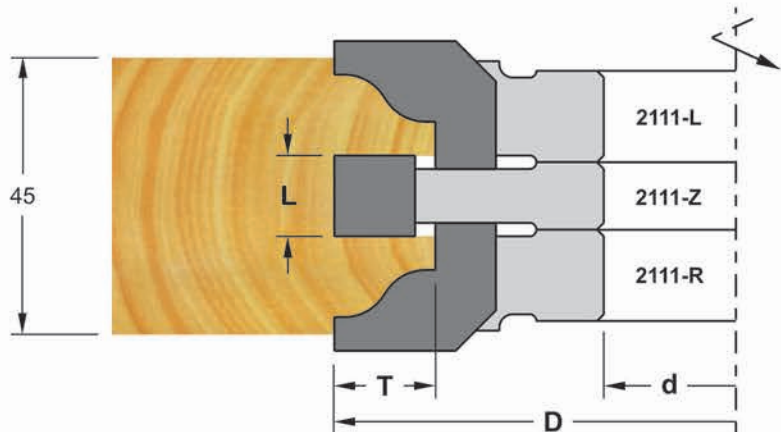

η τιμή του σετ περιλαμβάνει βίδα-καπελάκι-κλειδί /  
spanner, screw and reducing bushing are included

Part No	D	T	Z
2111-015R	130	15	4
2111-015L	130	15	4
2111-017R	130	17	4
2111-017L	130	17	4
2111-Z	130	L12	4
2111-315	130	SET	4
2111-317	130	SET	4

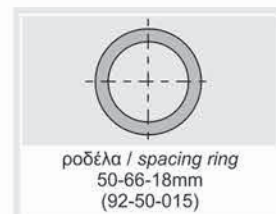

**HM**  
**d50**





**2111-3**  
με 3 εργαλεία  
(ΚΥΠΡΟΥ)

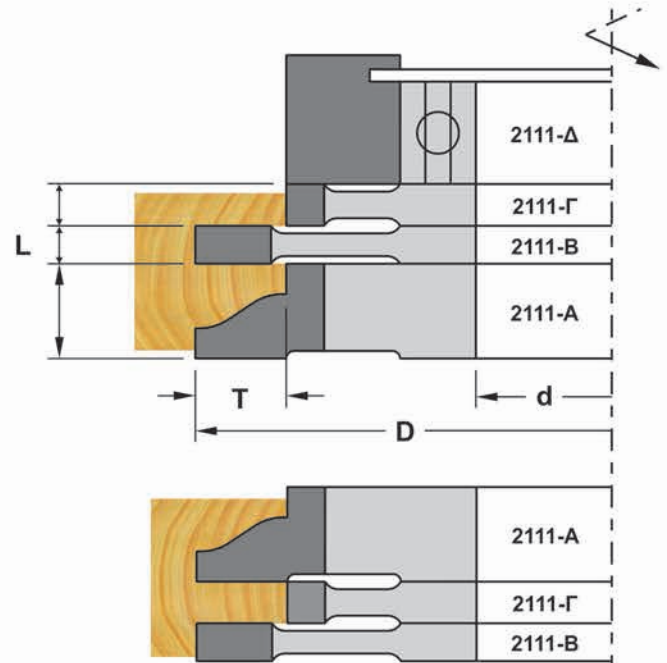

**2111-2**  
με 2 εργαλεία  
& ροδέλα

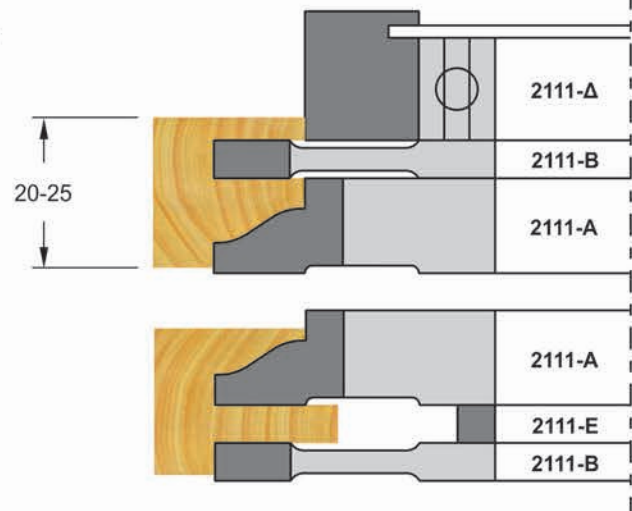

η τιμή του σετ περιλαμβάνει το ρουλεμάν / bearing is included

Part No	D	T	L	Z
2111-212	125	SET		4
2111-213	125	SET		4
2111-214	125	SET		4
2111-312	125	SET		4
2111-313	125	SET		4
2111-314	125	SET		4
2111-012A	125	12	12	4
2111-013A	125	13	12	4
2111-014A	125	14	12	4
2111-B	125	---	5.5	4
2111-012Γ	101	---	6.0	4
2111-013Γ	99	---	6.0	4
2111-014Γ	97	---	6.0	4
2111-012Δ	101	ΡΟΥΛΕΜΑΝ / bearing		
2111-013Δ	99	ΡΟΥΛΕΜΑΝ / bearing		
2111-014Δ	97	ΡΟΥΛΕΜΑΝ / bearing		
2111-006E		ΡΟΔΕΛΑ / spacing ring		

HM

d50

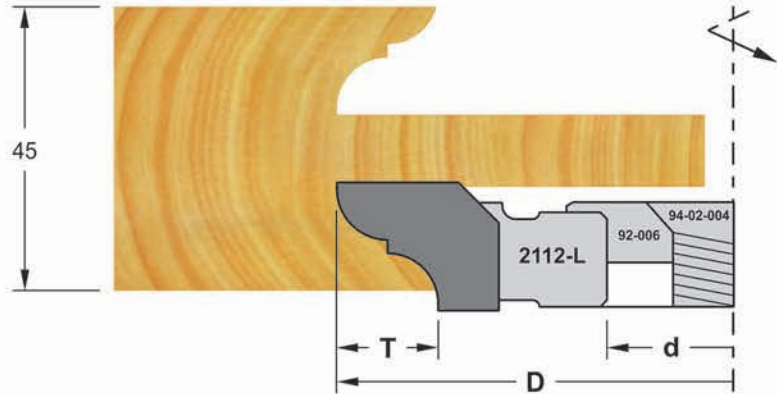

η τιμή της φρέζας δεν περιλαμβάνει βίδα-καπελάκι-κλειδί /  
spanner, screw and reducing bushing have extra price

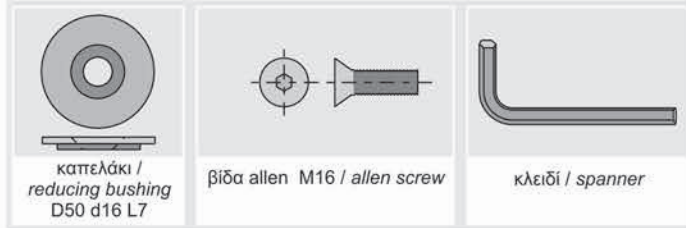

Part No	D	T	Z
2112-016L	130	16	4
2111-K	ΚΛΕΙΔΙ / spanner		
92-006	ΚΑΠΕΛΑΚΙ / reducing bushing		
B-02-004	ΒΙΔΑ ALLEN / allen screw		

**HM**

**d50**

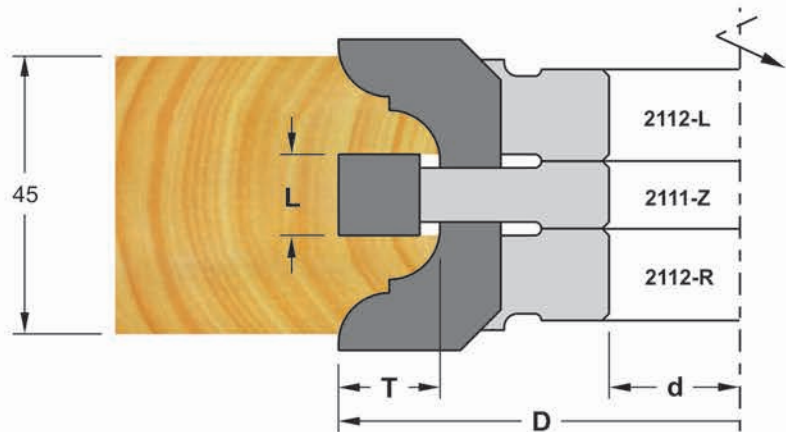
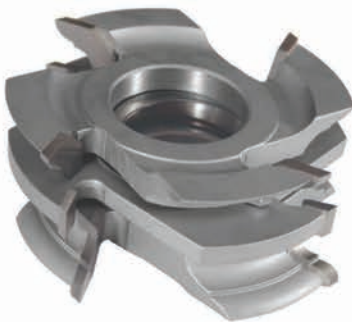

η τιμή του σετ περιλαμβάνει βίδα-καπελάκι-κλειδί /  
spanner, screw and reducing bushing are included

Part No	D	T	Z
2112-016R	130	16	4
2112-016L	130	16	4
2111-Z	130	L12	4
2112-316	130	SET	4

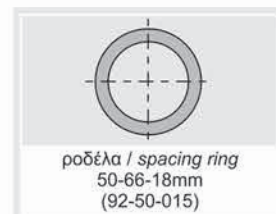

**HM**

**d50**



**2112-3**  
με 3 εργαλεία  
(ΚΥΠΡΟΥ)

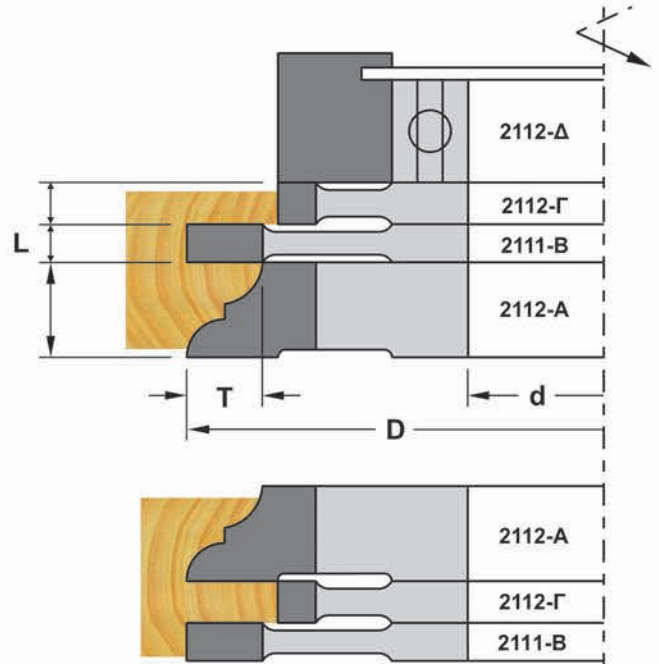

**2112-2**  
με 2 εργαλεία  
& ροδέλα

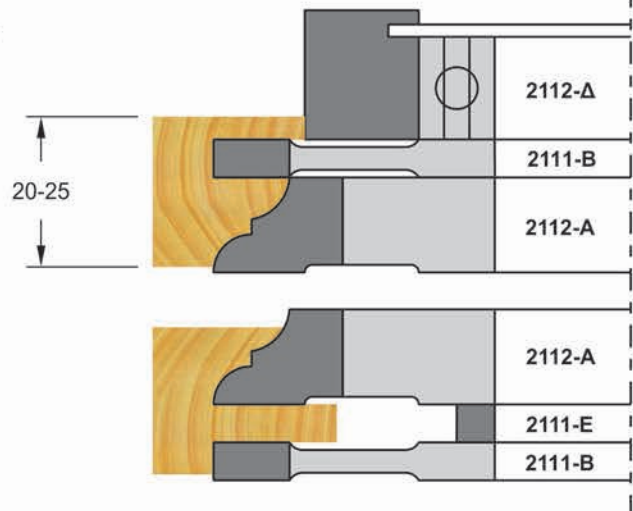

η τιμή του σετ περιλαμβάνει το ρουλεμάν / bearing is included

Part No	D	T	L	Z
2112-210	125	SET		4
2112-310	125	SET		4
2112-010A	125	10	14	4
2111-B	125	---	5.5	4
2112-010Γ	105	---	6.0	4
2112-010Δ	105	ΡΟΥΛΕΜΑΝ / bearing		
2111-006E		ΡΟΔΕΛΑ / spacing ring		



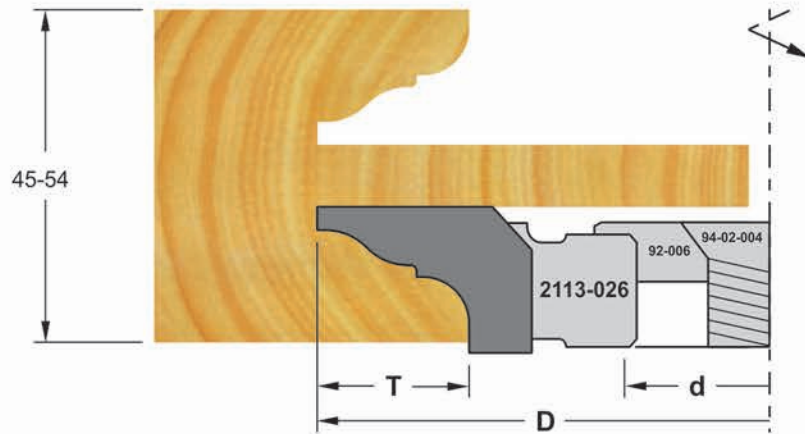

η τιμή της φρέζας δεν περιλαμβάνει βίδα-καπελάκι-κλειδί /  
spanner, screw and reducing bushing have extra price

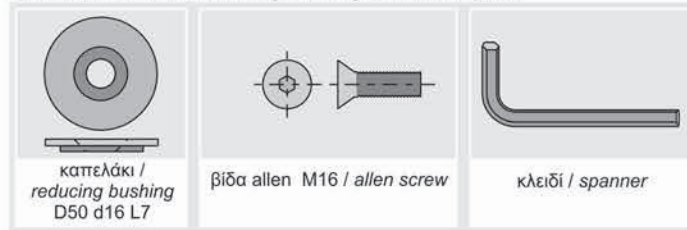

Part No	D	T	Z
2113-026L	150	25	4
2111-K	ΚΛΕΙΔΙ / spanner		
92-006	ΚΑΠΕΛΑΚΙ / reducing bushing		
B-02-004	ΒΙΔΑ ALLEN / allen screw		

**HM**

**d50**

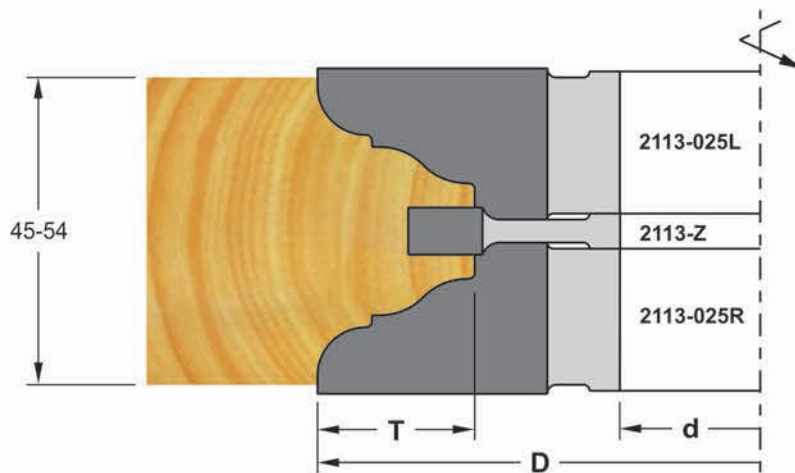

η τιμή του σετ δεν περιλαμβάνει βίδα-καπελάκι-κλειδί /  
spanner, screw and reducing bushing have extra price

Part No	D	T	Z
2113-025R	150	25	4
2113-025L	150	25	4
2113-Z	120	---	4
2113-325	SET		4

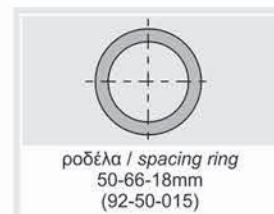

**HM**

**d50**



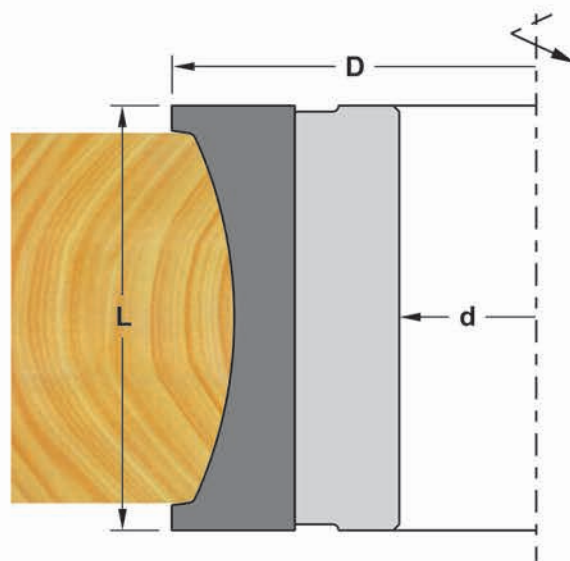

Part No	D	L	Z	ΞΥΛΟ / wood
2113-065	130	65	4	55
2113-070	130	70	4	60
2113-075	130	75	4	65
2113-080	130	80	4	70
2113-085	130	85	4	75
2113-090	130	90	4	80

HM

d50

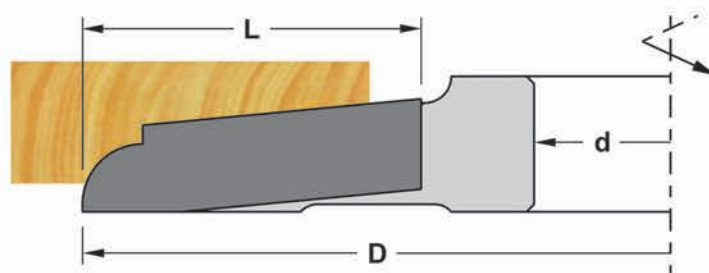

Part No	D	L	Z
2114-045	170	45	4
2114-055	200	55	4

HM

d50



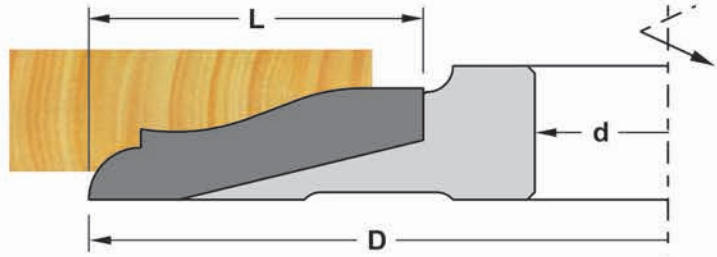

Part No	D	L	Z
2115-045	170	45	4
2115-055	200	55	4

**HM**

**d50**

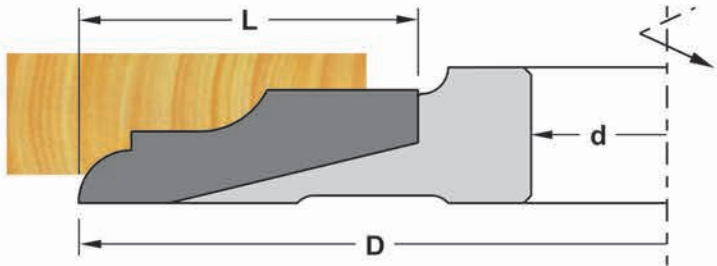
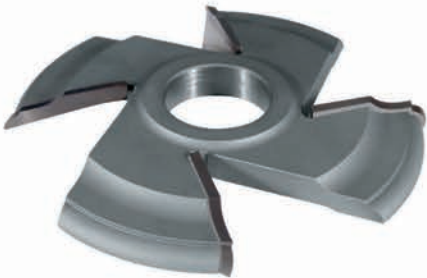

Part No	D	L	Z
2117-045	170	45	4
2117-055	200	55	4

**HM**

**d50**

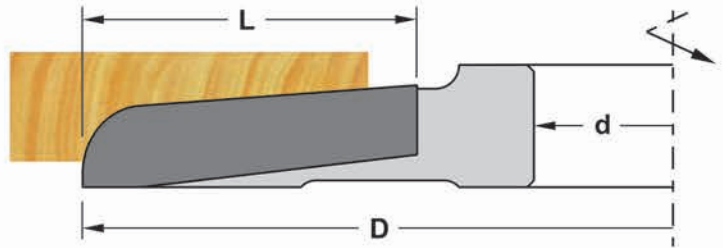
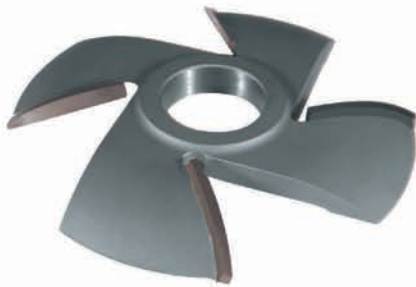

Part No	D	L	Z
2116-045A	170	45	4
2116-055	200	55	4

HM

d50

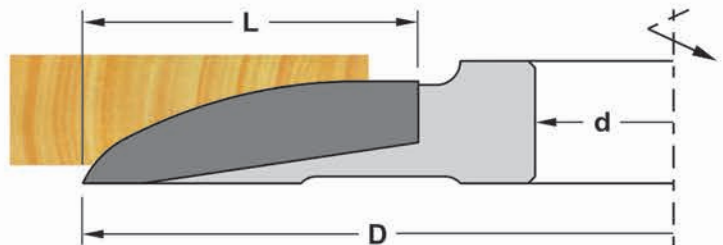

Part No	D	L	Z
2116-045B	170	45	4
2116-055Γ	200	55	4

HM

d50

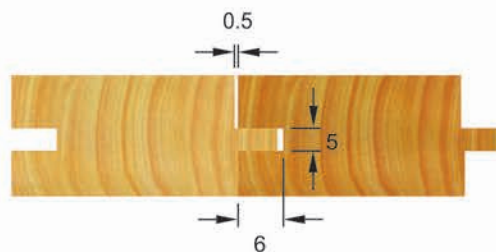
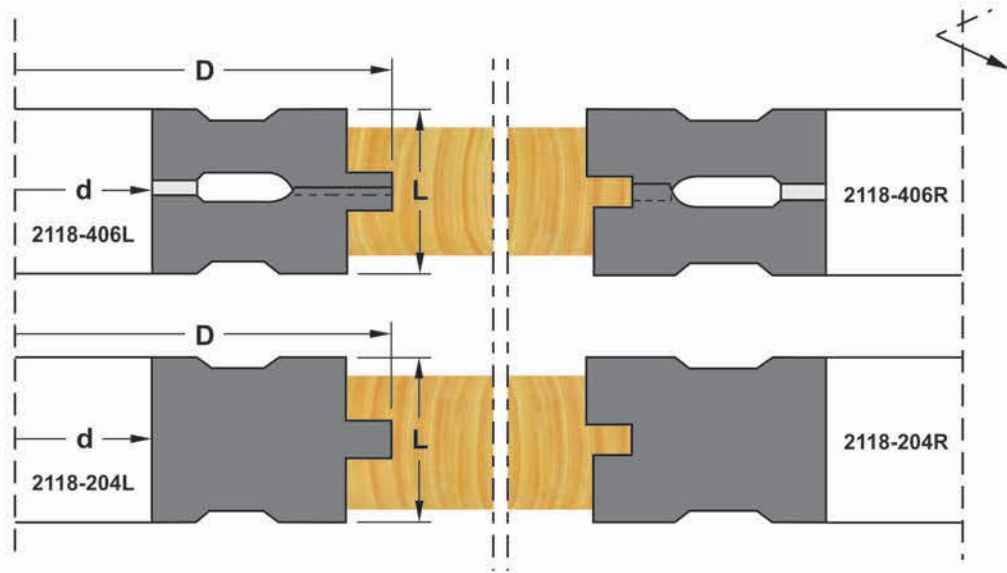

Part No	D	L	d	Z	
2118-204	125	30	50	4	
2118-406	160	30	40/60	6	με σπειρωμα / with clamping bushing
2111-406A	160	30	40/60	6	με ροδέλες / with spacer rings

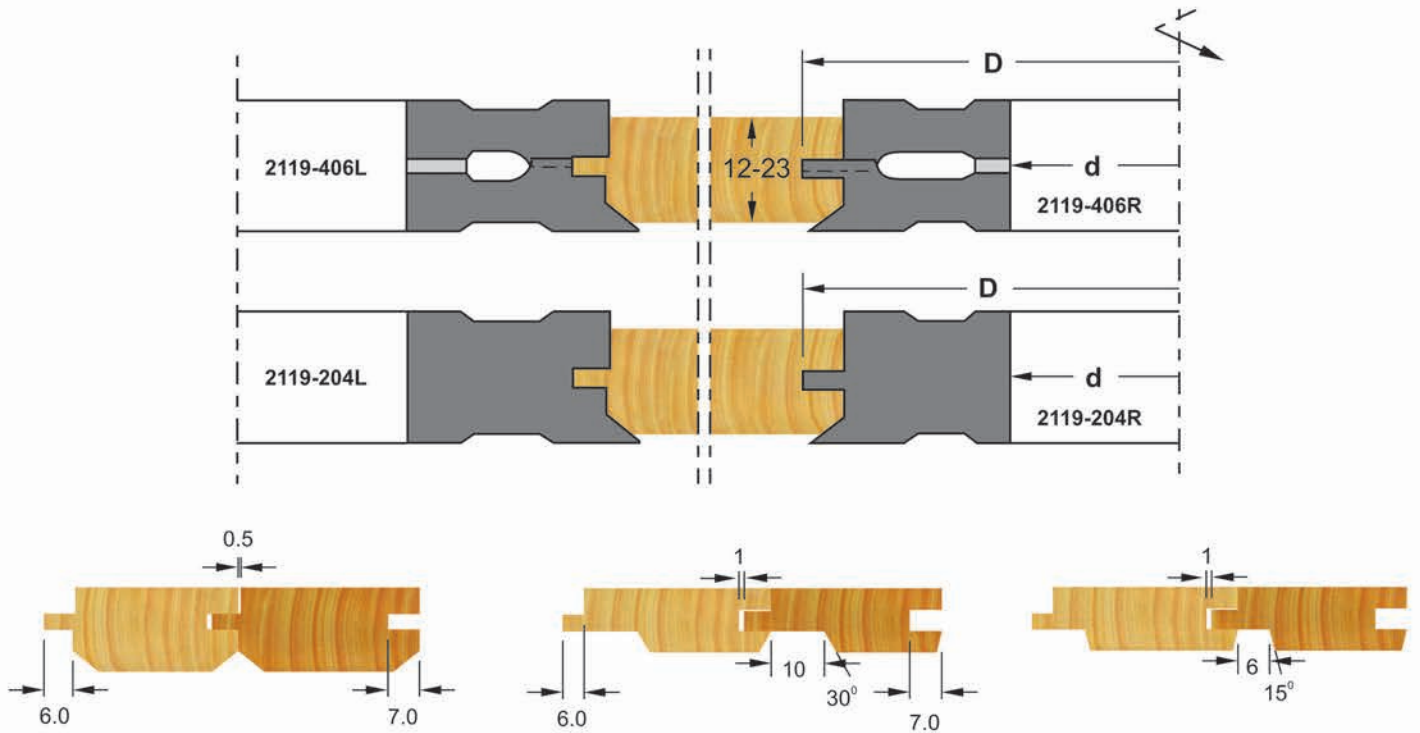

Part No	D	d	Z	
2119-204	140	50	4	
2119-406	160	40	6	με σπειρωμα / with clamping bushing
2119-406A	160	40	6	με ροδέλες / with spacer rings

HM

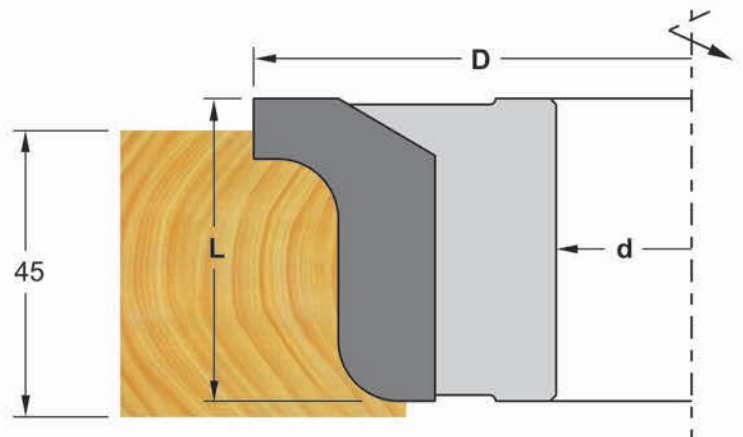

Part No	D	L	Z
2120-050	150	50	4

HM

d50

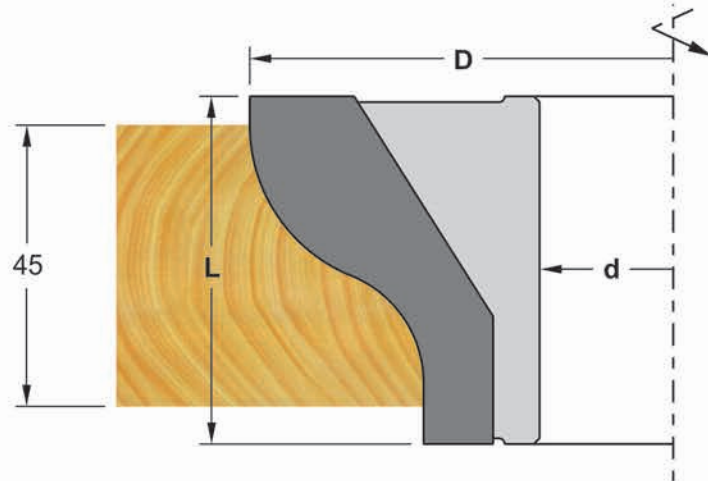
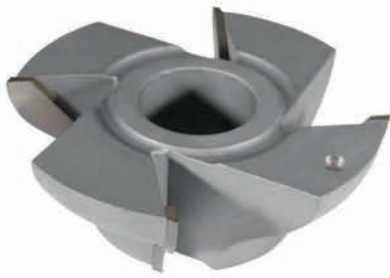

HM

d50

Part No	D	L	Z
2121-050	150	50	4

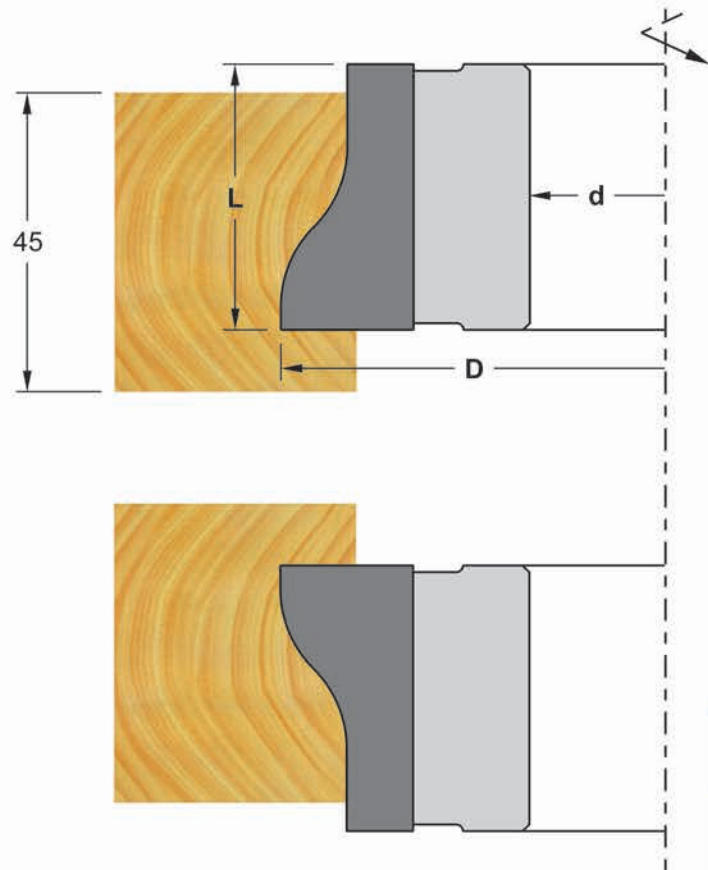

HM

d50

Part No	D	L	Z
2122-040	125	40	4



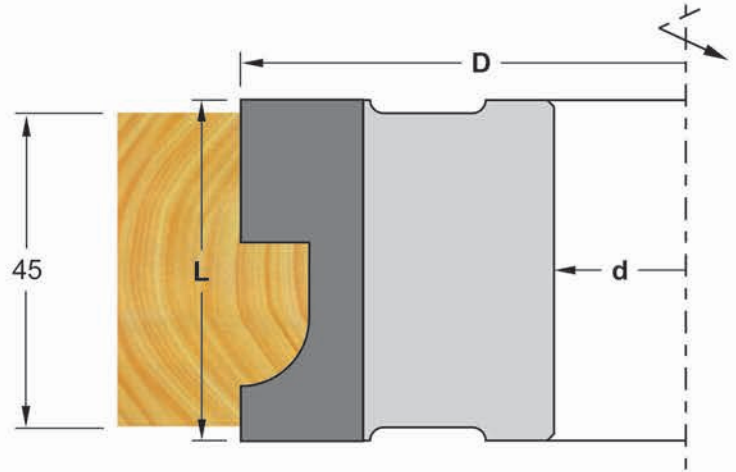

HM

d50

Part No	D	L	Z
2123-050	125	50	4

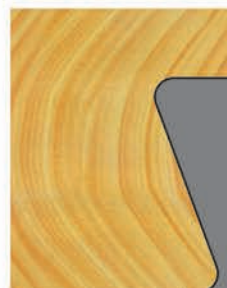
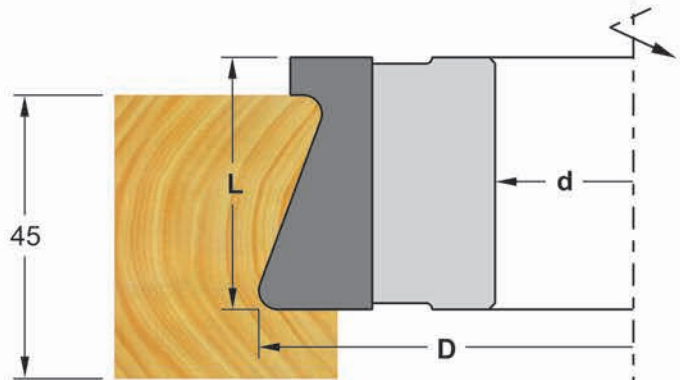

HM

d50

Part No	D	L	Z
2124-040	125	40	4

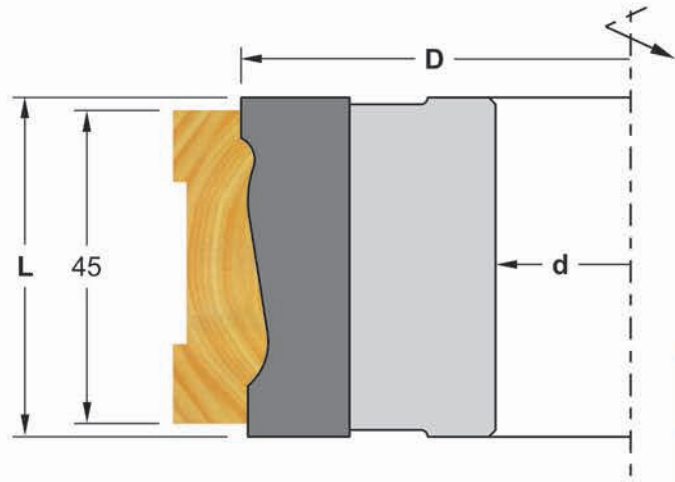

**HM**

**d50**

Part No	D	L	Z
2125-050	125	50	4

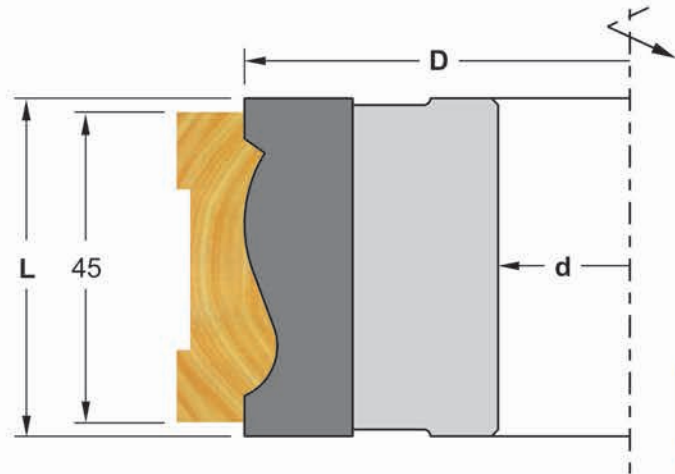

**HM**

**d50**

Part No	D	L	Z
2125-051	125	50	4

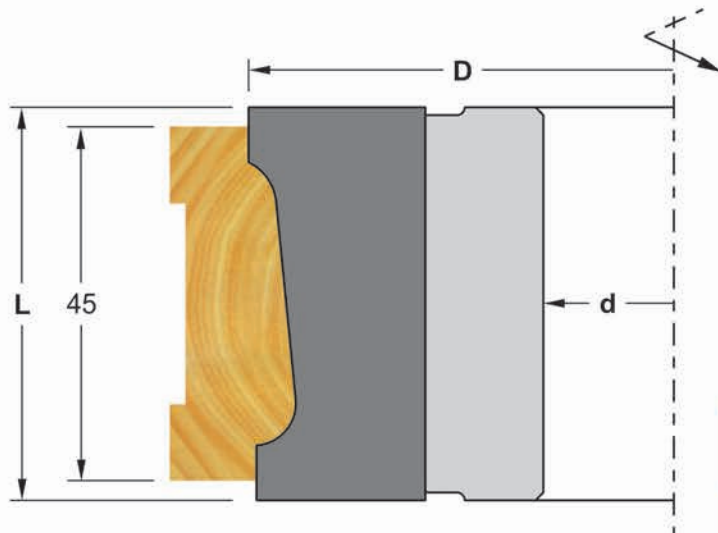

**HM**

**d50**

Part No	D	L	Z
2125-052	125	50	4

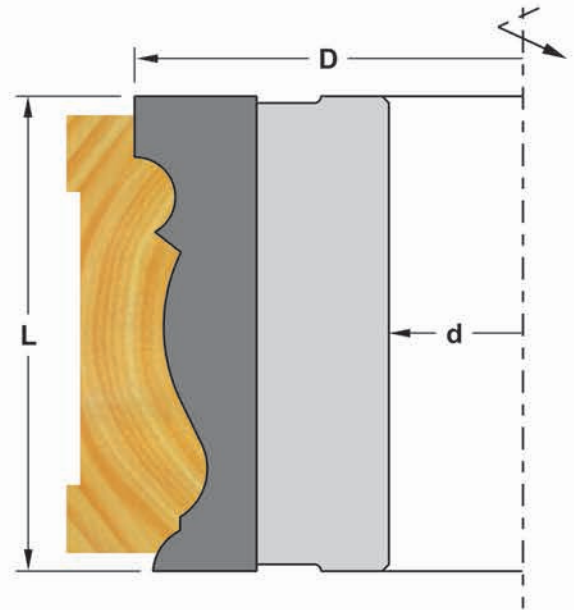

Part No	D	L	Z
2126-070	125	70	4

HM	d50
----	-----

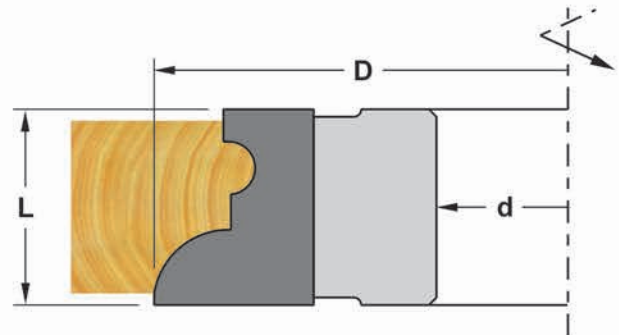

Part No	D	L	Z
2127-020	125	20	4
2127-025	125	25	4

HM	d50
----	-----

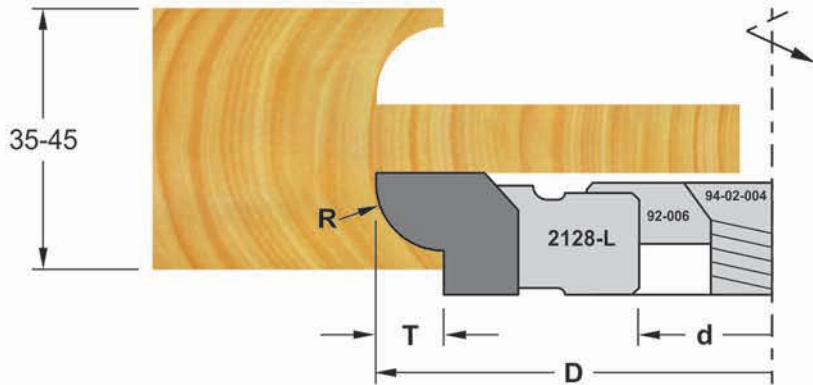

η τιμή της φρέζας δεν περιλαμβάνει βίδα-καπελάκι-κλειδί /  
spanner, screw and reducing bushing have extra price

Part No	D	R	T	Z
2128-008L	125	8	8	4
2128-010L	125	10	10	4
2128-015L	125	15	15	4
2111-K	ΚΛΕΙΔΙ / spanner			
92-006	ΚΑΠΕΛΑΚΙ / reducing bushing			
B-02-004	ΒΙΔΑ ALLEN / allen screw			

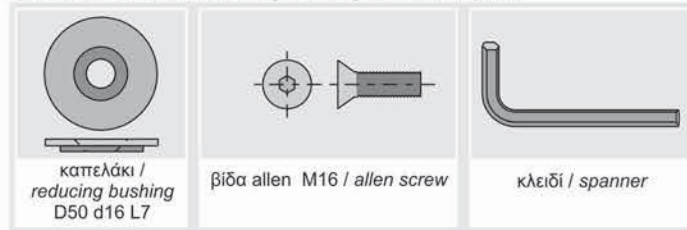

**HM**

**d50**

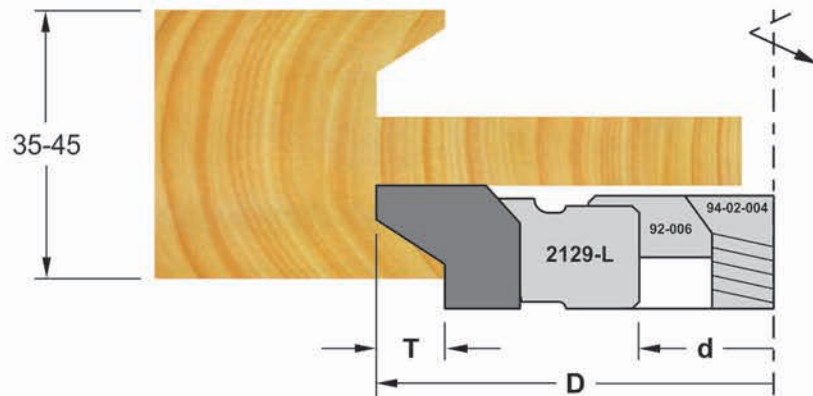
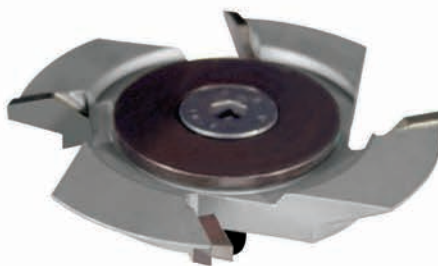

η τιμή της φρέζας δεν περιλαμβάνει βίδα-καπελάκι-κλειδί /  
spanner, screw and reducing bushing have extra price

Part No	D	T	Z
2129-010L	125	10	4
2129-015L	125	15	4
2111-K	ΚΛΕΙΔΙ / spanner		
92-006	ΚΑΠΕΛΑΚΙ / reducing bushing		
B-02-004	ΒΙΔΑ ALLEN / allen screw		

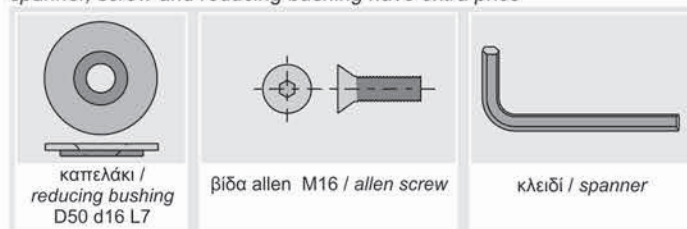

**HM**

**d50**



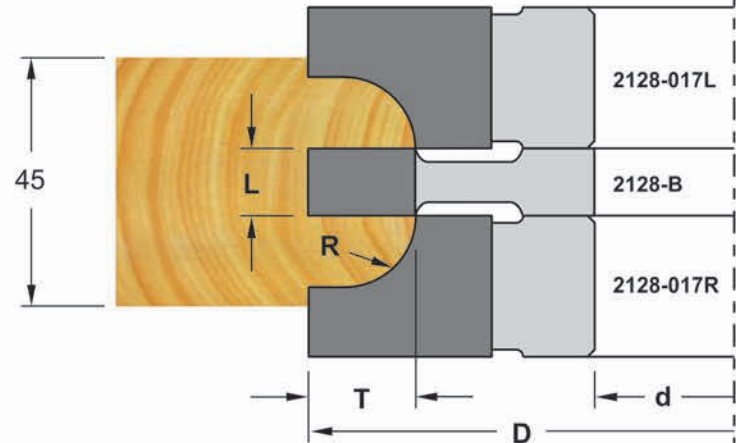
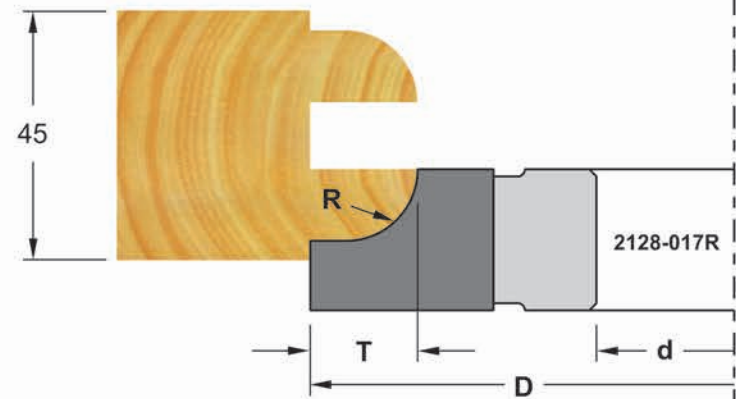
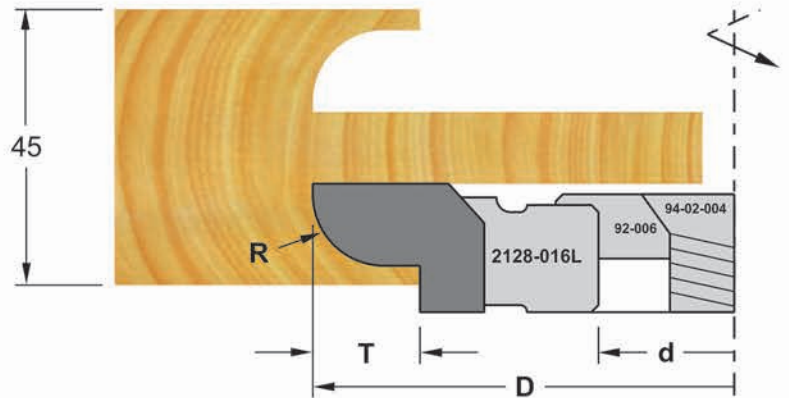
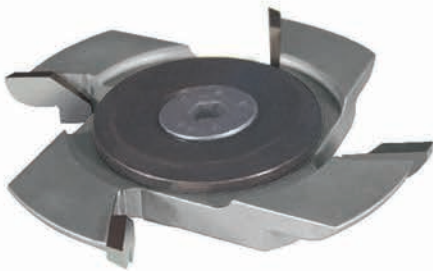

Part No	D	R/T	Z
2128-016L	130	10/15	4
2128-017R	130	10/15	4
2128-017L	130	10/15	4
2128-B	130	L14	4
2128-215	SET		4
2111-K	ΚΛΕΙΔΙ / spanner		
92-006	ΚΑΠΕΛΑΚΙ / reducing bushing		
B-02-004	ΒΙΔΑ ALLEN / allen screw		

η τιμή του σετ περιλαμβάνει βίδα-καπελάκι-κλειδί /  
spanner, screw and reducing bushing are included

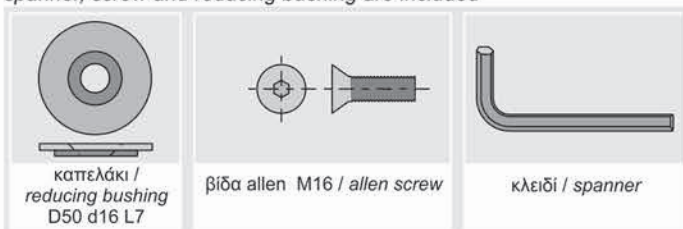

**HM**  
**d50**



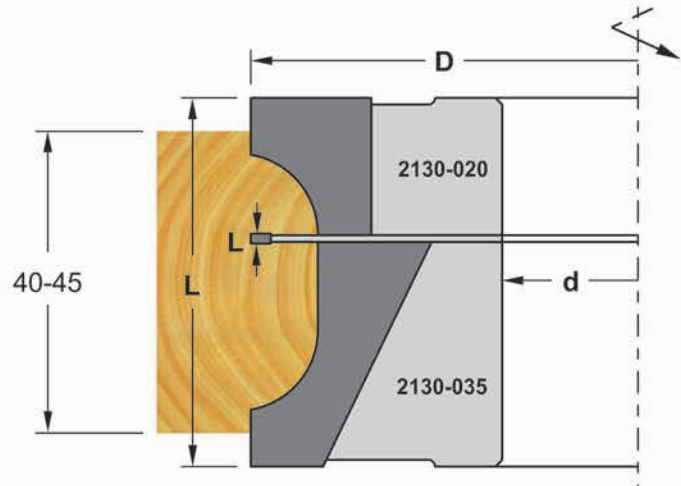
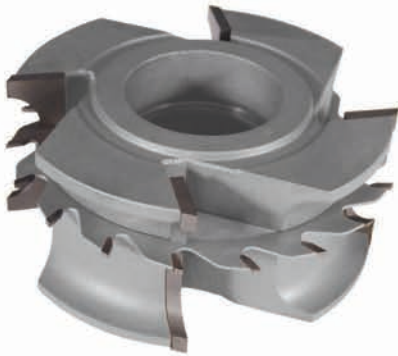

η τιμή του σετ δεν περιλαμβάνει τον δίσκο /  
circular saw blade has extra price

Part No	D	L	Z
2130-020	125	20	4
2130-035	125	35	4
1034-125-50	125	1.5	18
2130-050SET	125	SET	

**HM**

**d50**

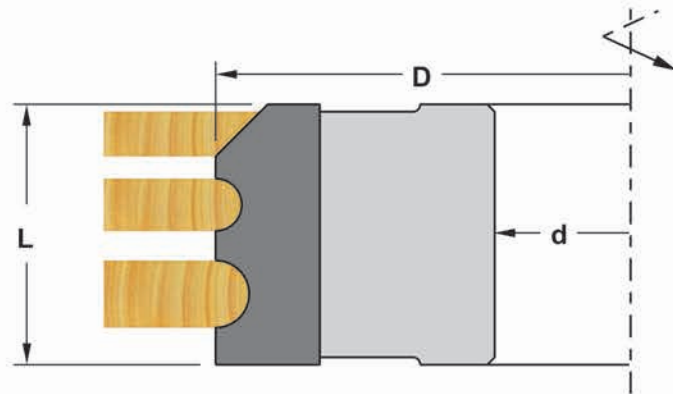

Part No	D	L	Z
2131-035	125	35	4

**HM**

**d50**

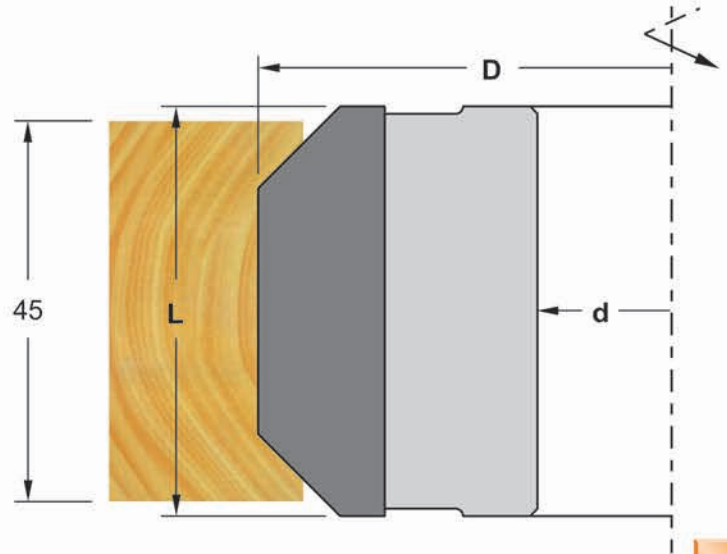
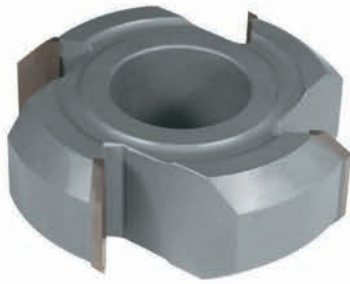

HM

d50

Part No	D	L	Z
2132-045	125	50	4

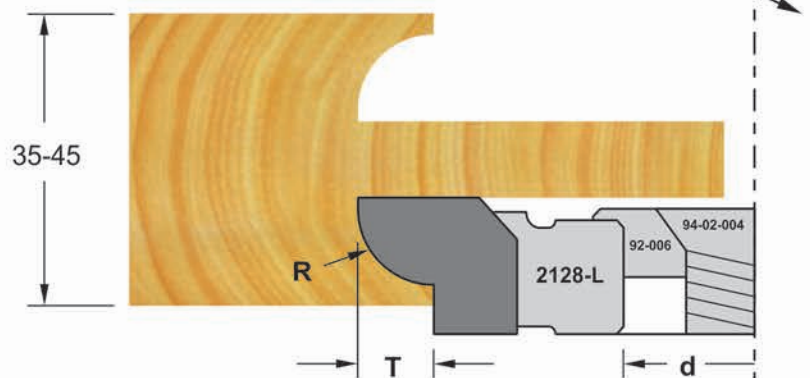
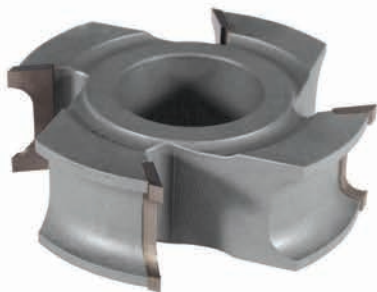

η τιμή της φρέζας δεν περιλαμβάνει βίδα-καπελάκι-κλειδί /  
spanner, screw and reducing bushing have extra price

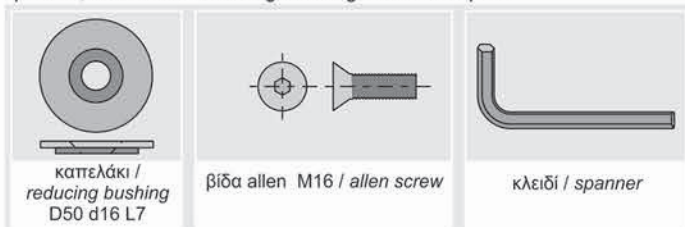

Part No	D	L	Z
2133-040	125	40	4
2128-008L	125	R8	4
2111-K	ΚΛΕΙΔΙ / spanner		
92-006	ΚΑΠΕΛΑΚΙ / reducing bushing		
B-02-004	ΒΙΔΑ ALLEN / allen screw		

HM

d50

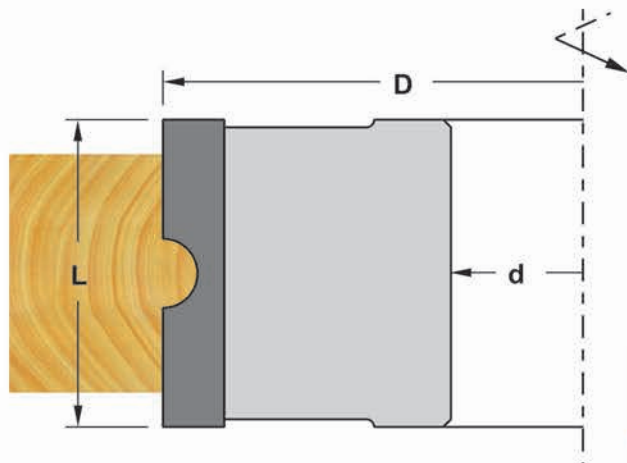
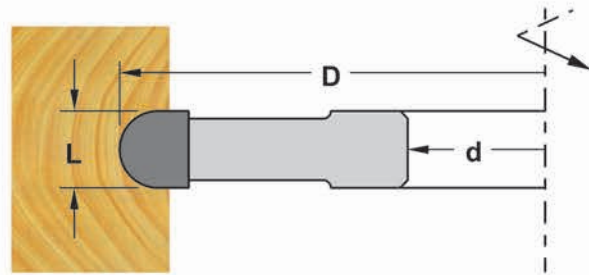

**HM**  
**d50**

Part No	D	L	Z
2104-010	125	10	4
2133-040A	125	40	4
2133-040SET	125	40	4

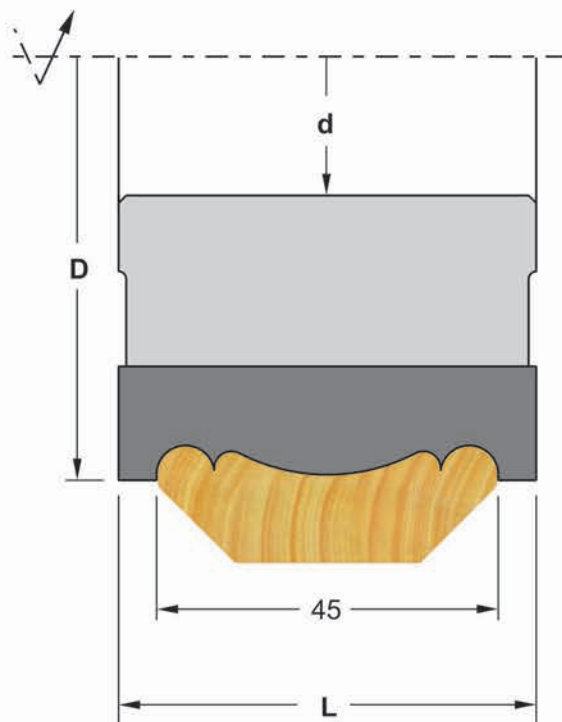

**HM**  
**d50**

Part No	D	L	Z
2134-050	125	55	4

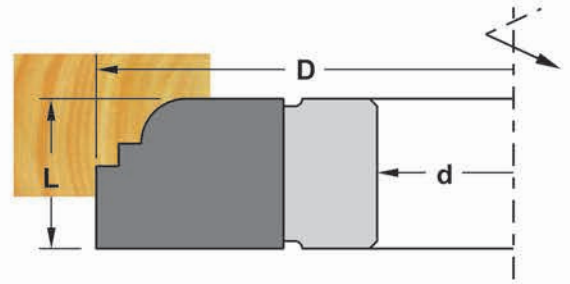

Part No	D	L	Z
2135-020	125	20	4

HM	d50
----	-----

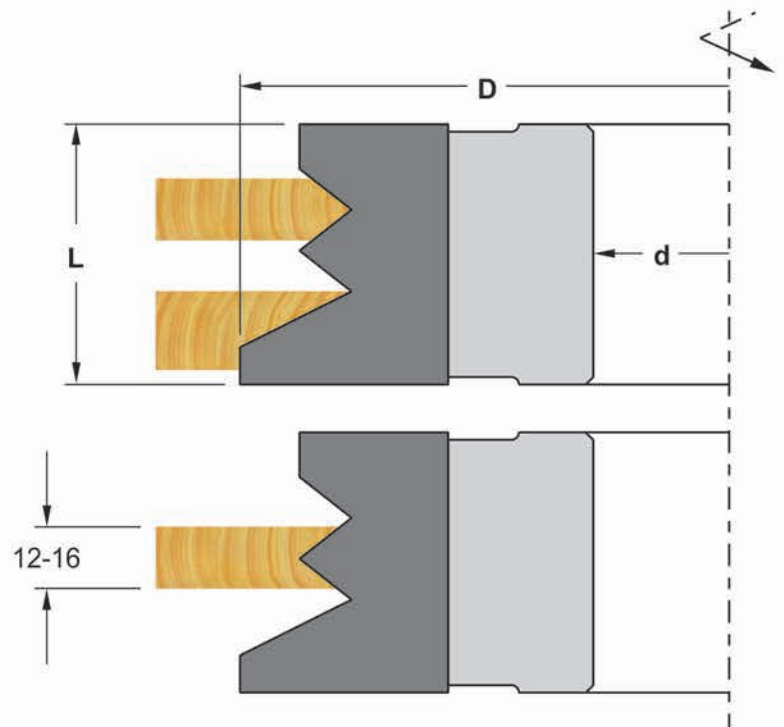

Part No	D	L	Z
2136-035	145	35	4

HM	d50
----	-----



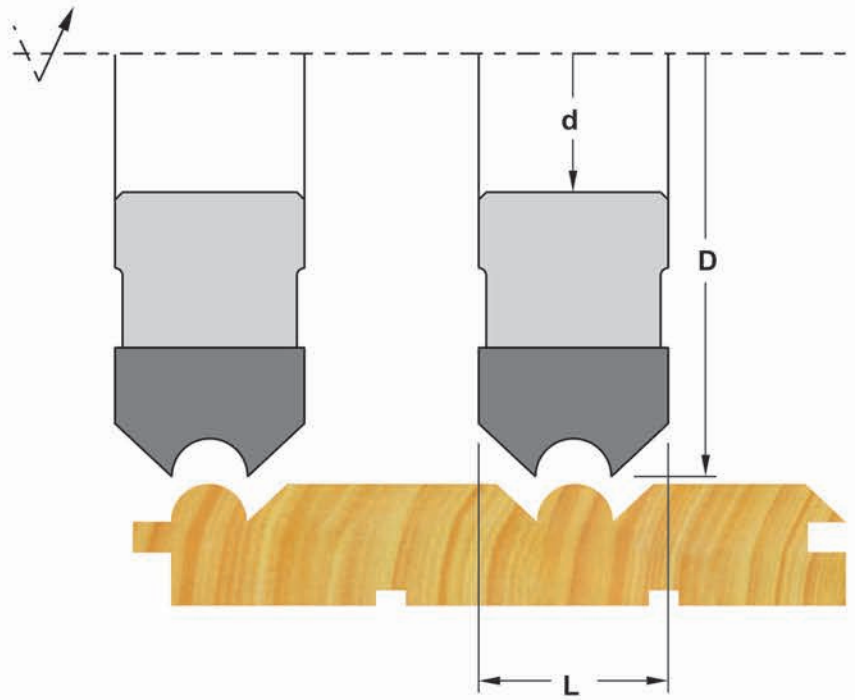

Part No	D	L	Z
2137-020	125	20	4

**HM**

**d50**

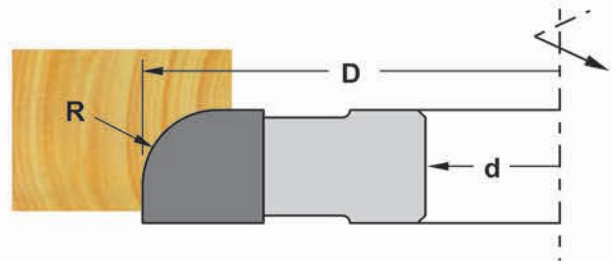

Part No	D	R	Z
2138-010	125	10	4
2138-015	130	15	4
2138-020	140	20	4
2138-025	150	25	4
2138-030	160	30	4
2138-035	170	35	4
2138-040	180	40	4
2138-050	200	50	4
2138-200	130	35	4

χούφτα τελάρου μελισσοκομίας

**HM**

**d50**

SS 139

ΜΠΙΖΟΥΤΙΕΡΑ ΜΙΚΡΗ / Panel Raising Cutter

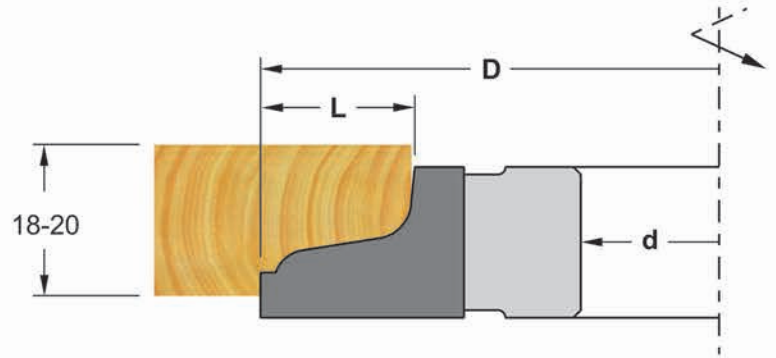

Part No	D	L	Z
2139-020	135	20	4

HM

d50

SS 140

ΜΠΙΖΟΥΤΙΕΡΑ ΡΑΔΙΟΥ / Panel Raising Cutter

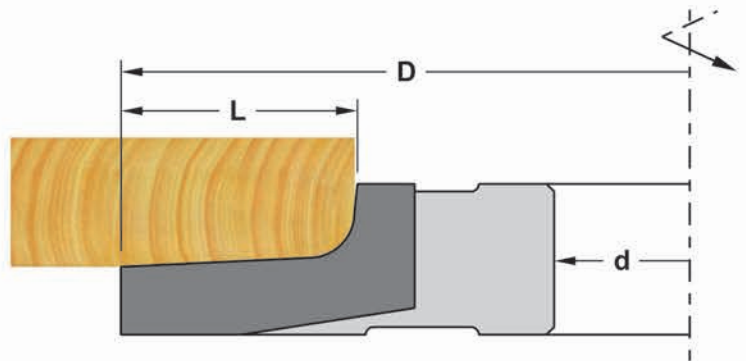

Part No	D	L	Z
2140-020	170	35	4

HM

d50

SS 141

ΜΠΙΖΟΥΤΙΕΡΑ ΜΕΓΑΛΗ / Panel Raising Cutter

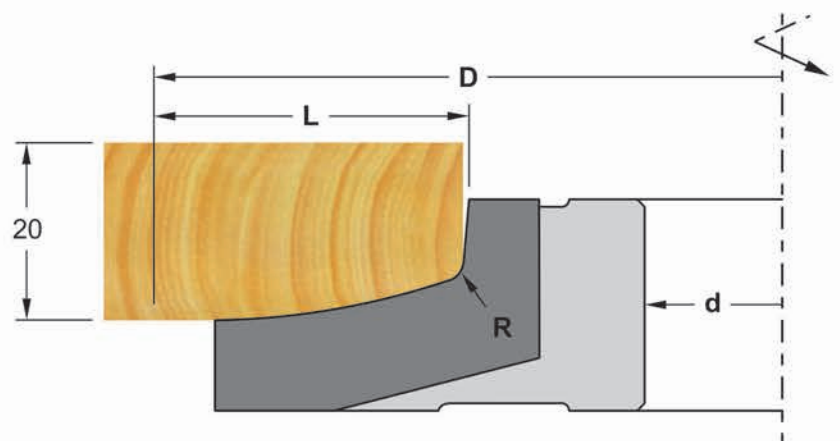

Part No	D	L	R	Z
2141-035	170	35	6.5	4
2141-036	170	35	3	4

HM

d50

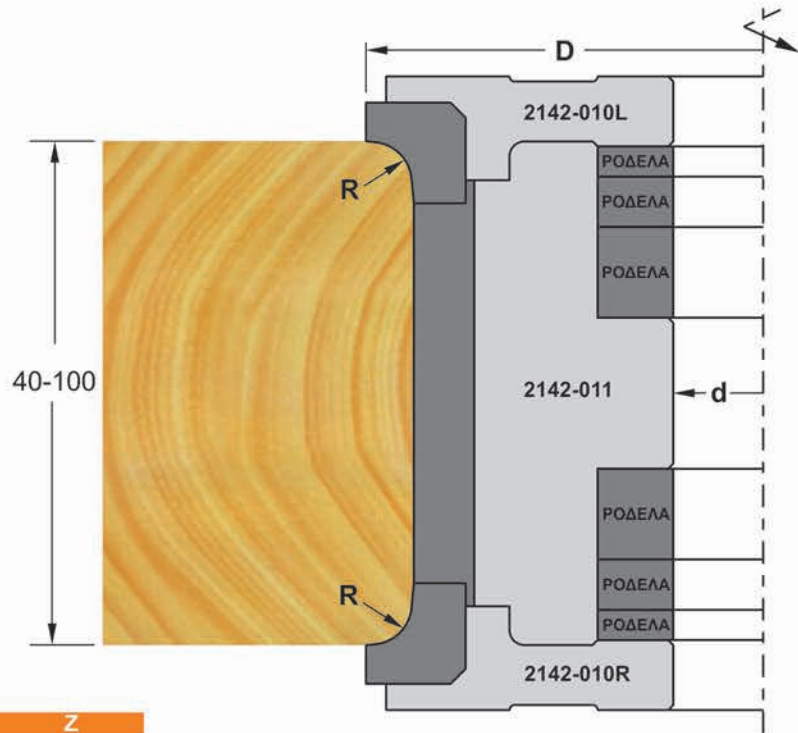

Part No	D	R	Z
2142-010L	156	8	4
2142-010R	156	8	4
2142-011	140	---	4
2142-013	156/140	SET	4

**HM**

**d50**

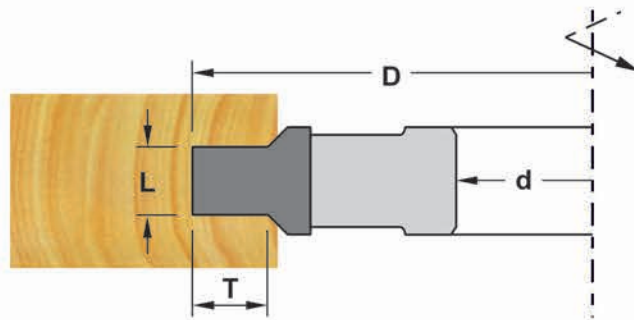

Part No	D	L	Z	T
2143-015	120	9	4	10

**HM**

**d50**

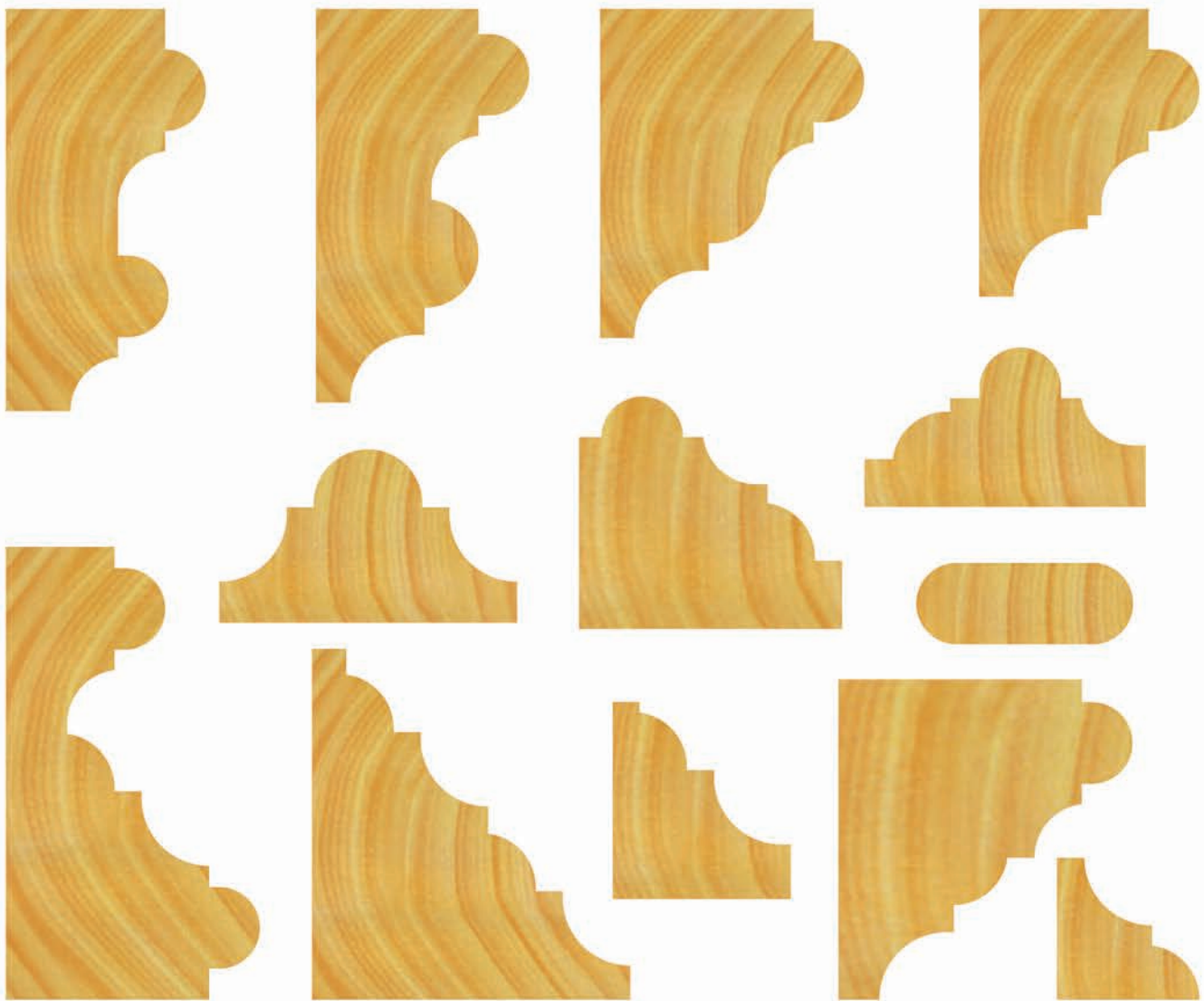
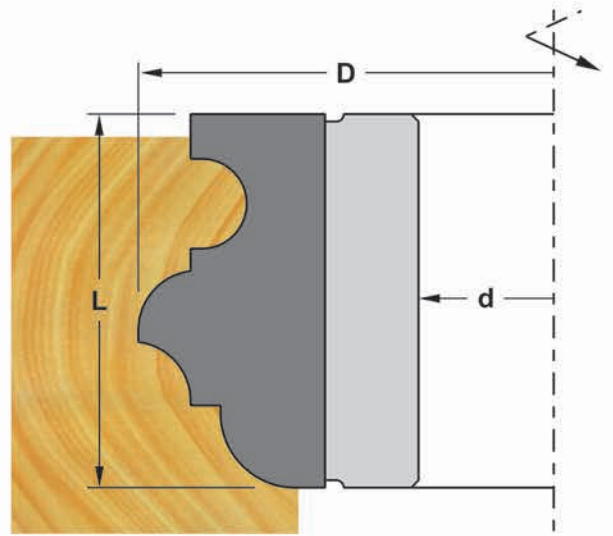

Part No	D	L	Z
2150-050	140	50	4

HM d50



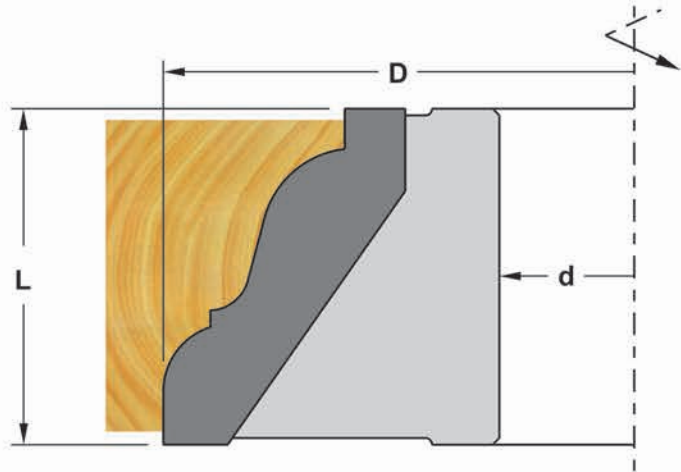

Part No	D	L	Z
2151-050	150	50	4

**HM**

**d50**

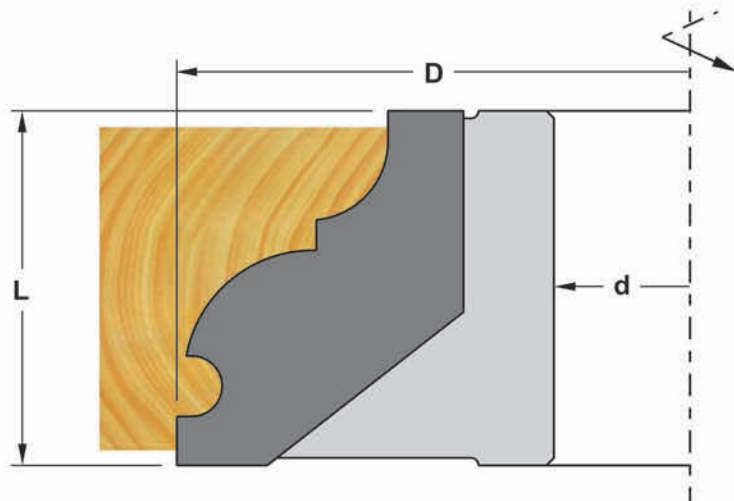

Part No	D	L	Z
2152-045	150	45	4

**HM**

**d50**

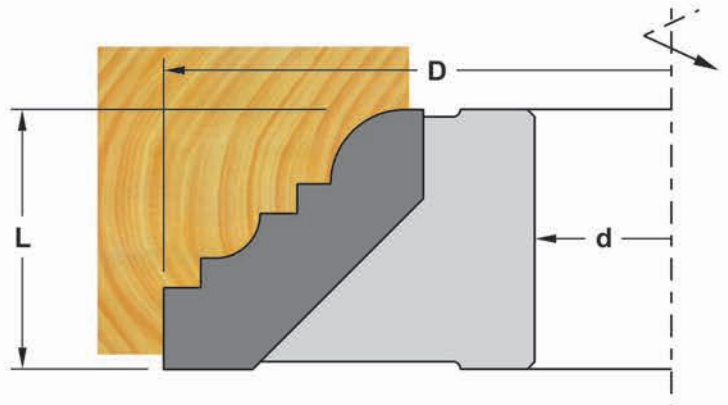

Part No	D	L	Z
2153-035	150	35	4

**HM** **d50**

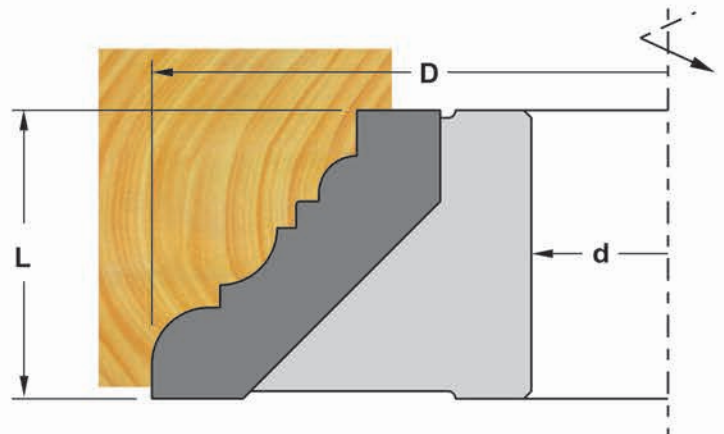

Part No	D	L	Z
2154-035	150	35	4

**HM** **d50**

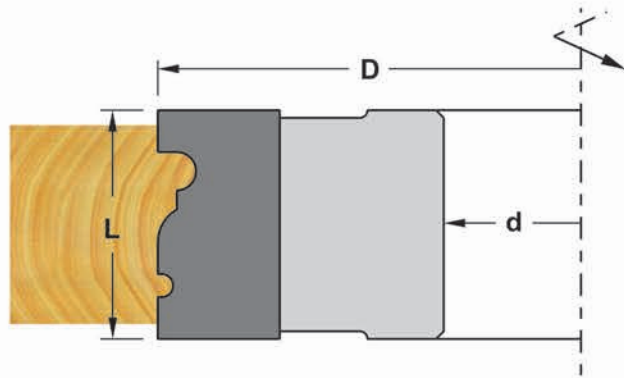

Part No	D	L	Z
2155-030	125	30	4

**HM**

**d50**

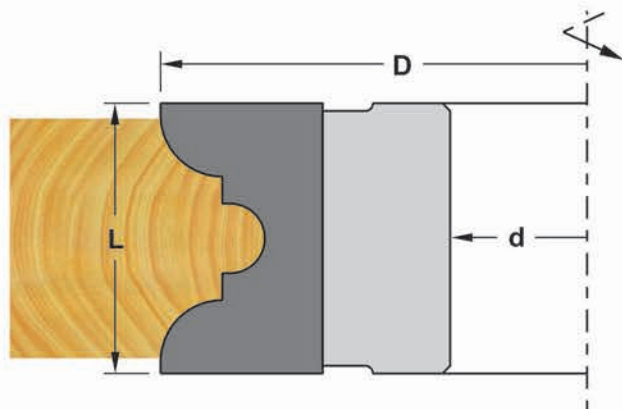

Part No	D	L	Z
2156-035	125	35	4

**HM**

**d50**

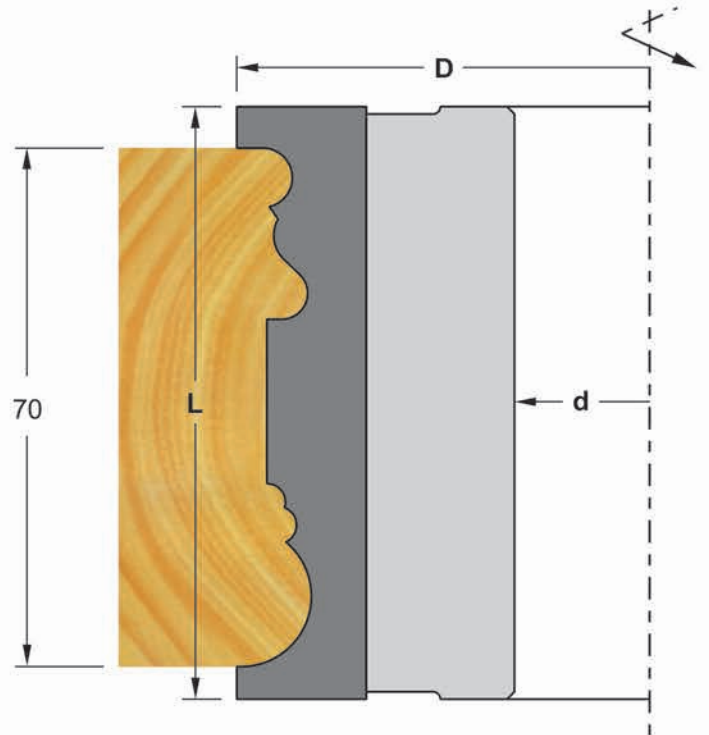

Part No	D	L	Z
2157-080	125	80	4

HM d50

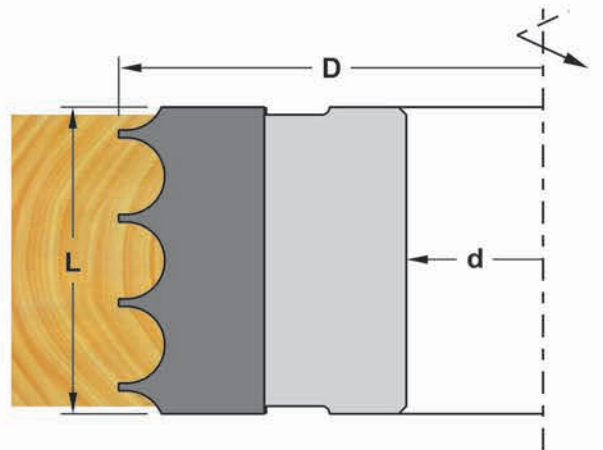

Part No	D	L1	L	Z
2158-030	125	Γ10/2	35	4
2158-031	125	B8/3	35	4
2158-032	125	A6/3	30	4
2158-040	125	10/3	45	4

HM d50



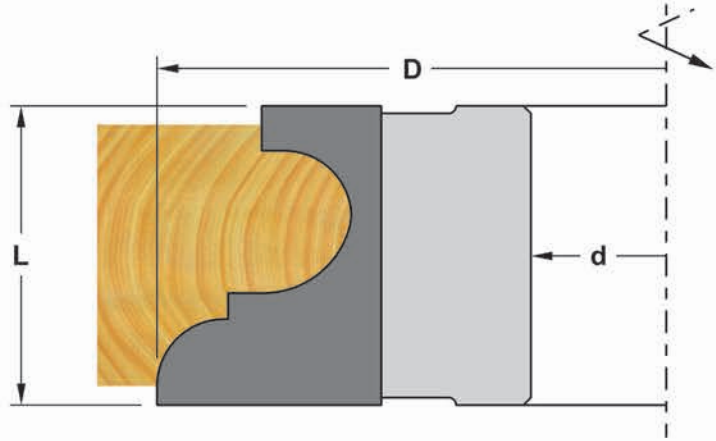

Part No	D	L	Z
2159-040	150	40	4

**HM**

**d50**

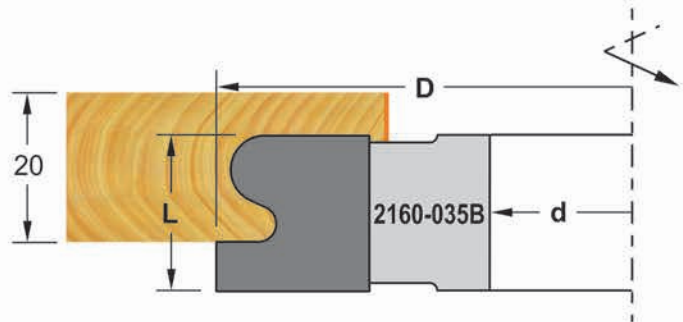
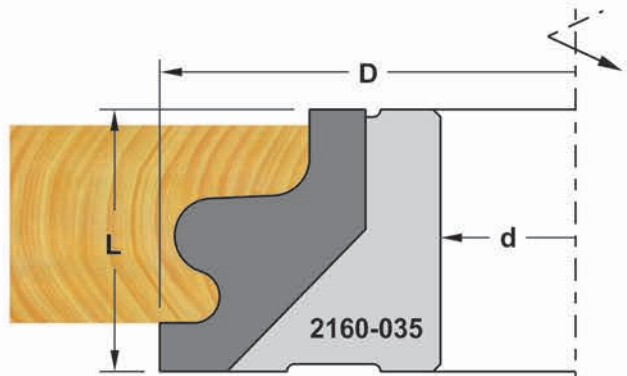

Part No	D	L	Z
2160-035	125	35	4
2160-035B	140	20	4

**HM**

**d50**

SS 161

ΚΟΥΠΑΣΤΗ / Handrail Profile Cutter

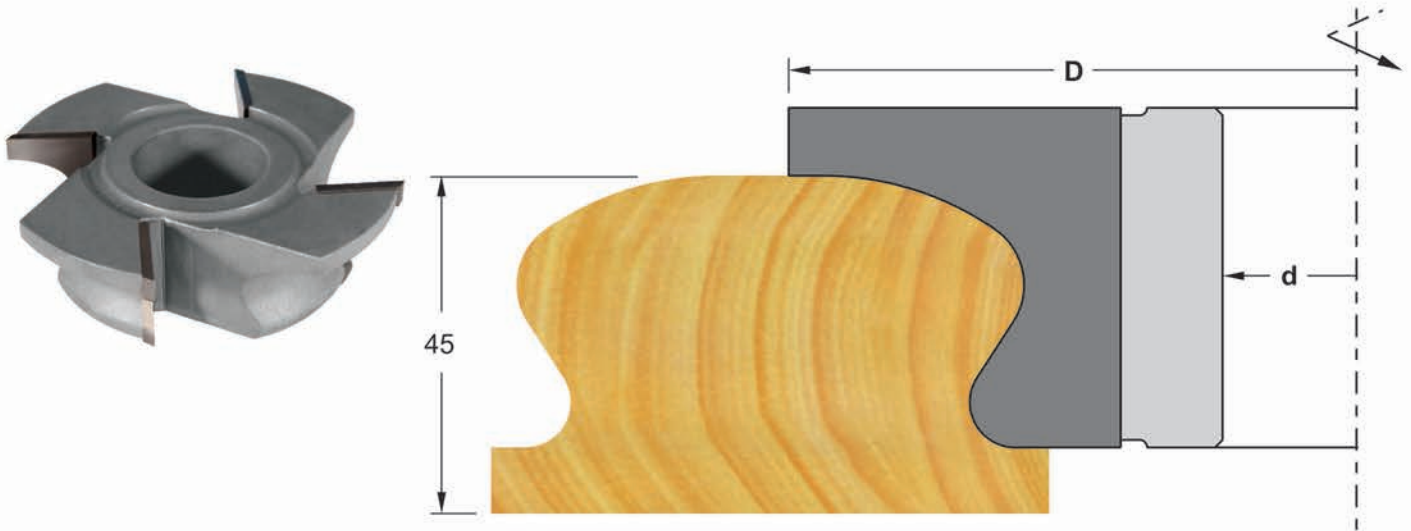

Part No	D	Z
2161-045	165	4

HM	d50
----	-----

SS 162

ΚΟΥΠΑΣΤΗ / Handrail Profile Cutter

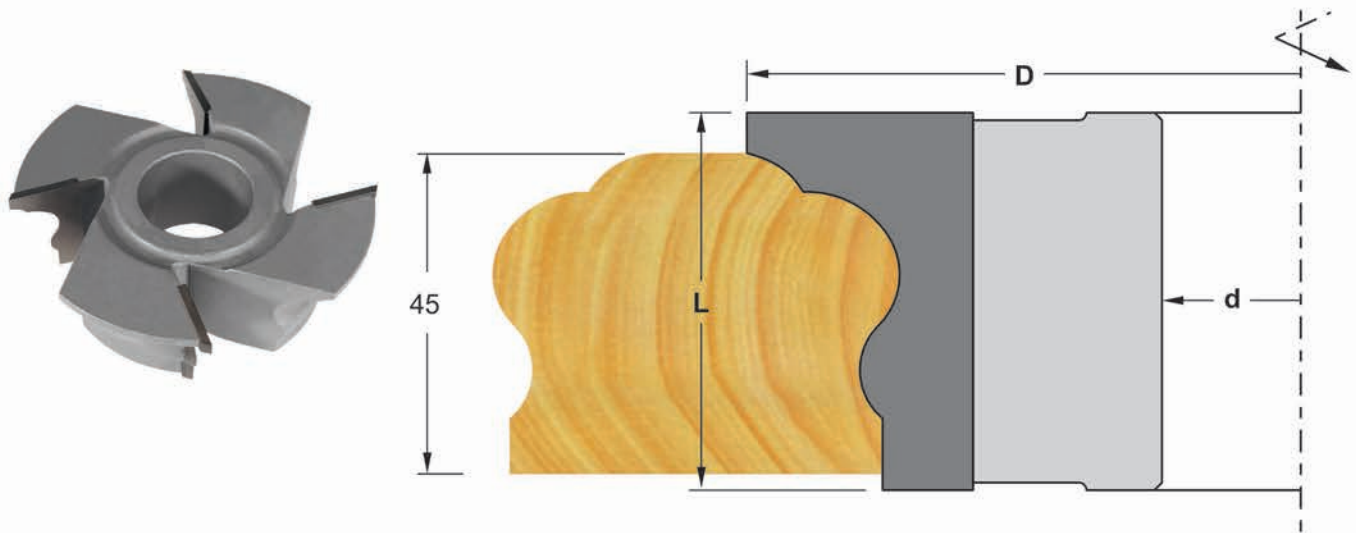

Part No	D	L	Z
2162-050	160	50	4

HM	d50
----	-----

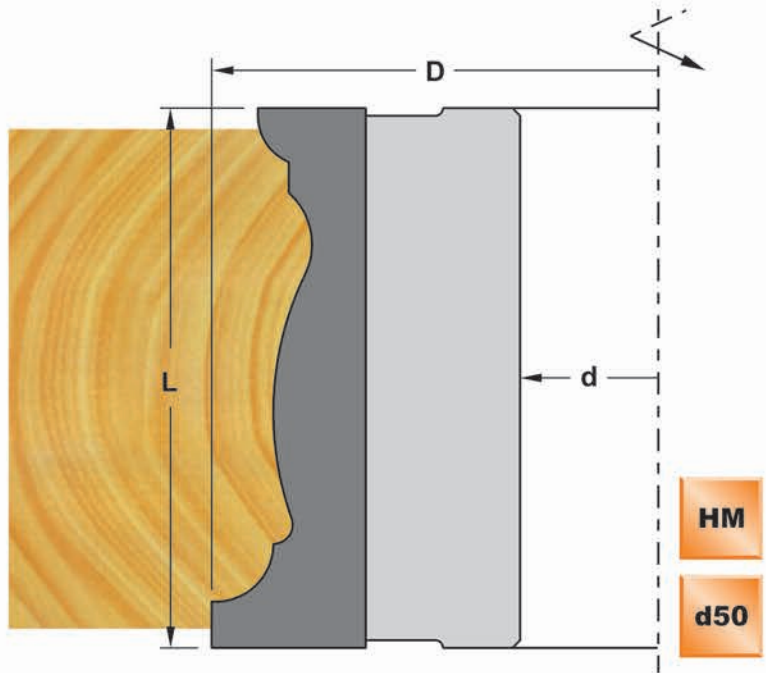

Part No	D	L	Z
2163-070	130	70	4

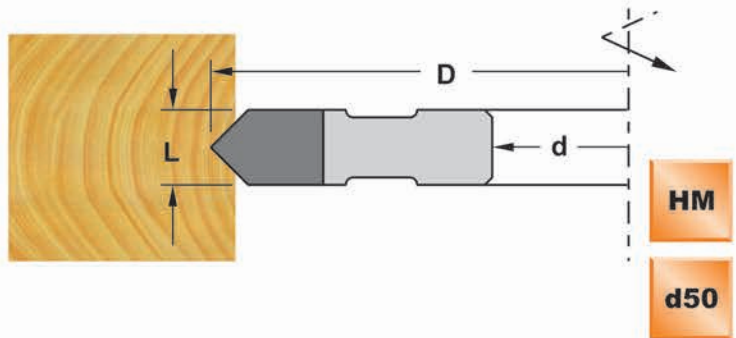

Part No	D	L	Z
2164-010	125	10	4

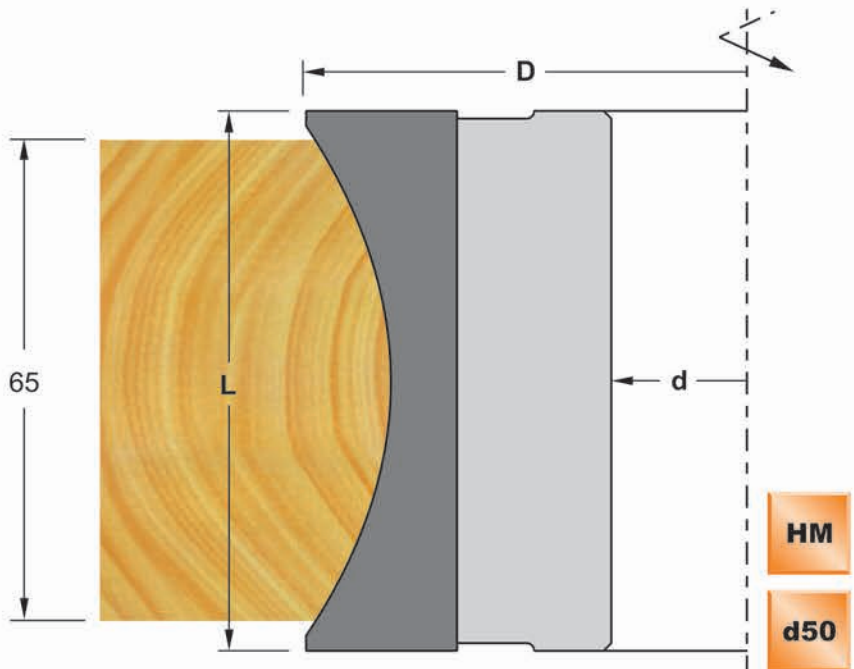

Part No	D	L	Z
2164-075	130	75	4

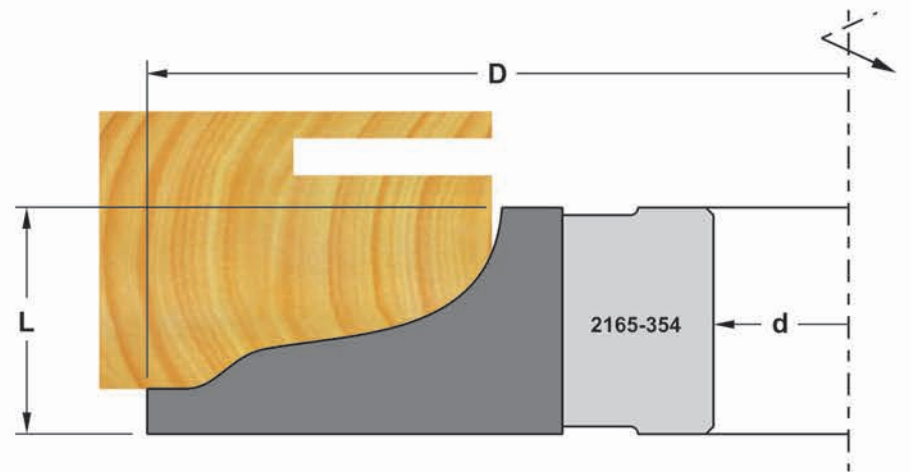
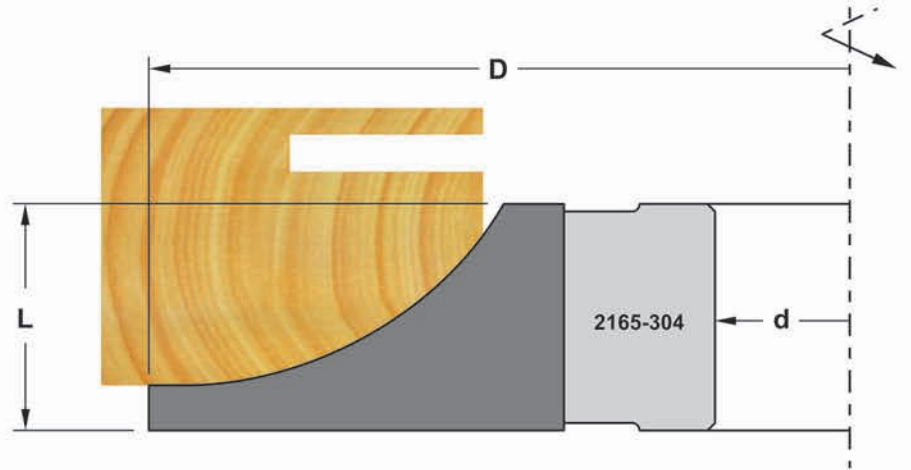
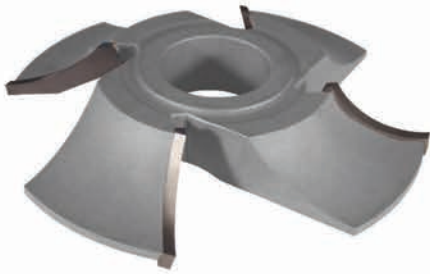

Part No	D	L	Z
2165-304	200	30	4
2165-354	200	35	4

HM d50

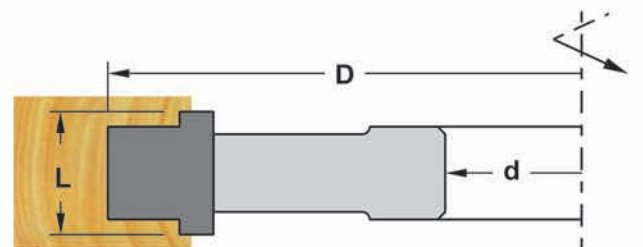

Part No	D	L	Z
2166-204	140	16.3-3/12.3-10	4

HM d50



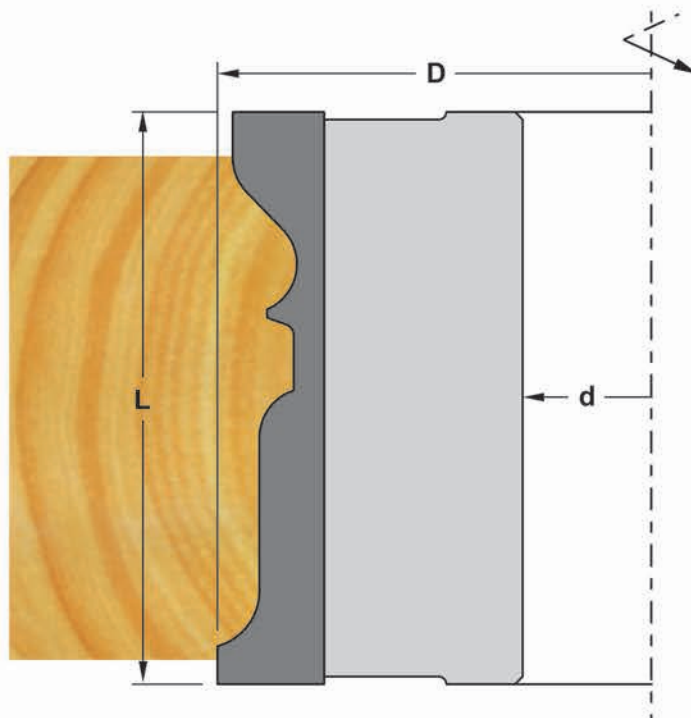

Part No	D	L	Z
2167-075	130	75	4

HM

d50

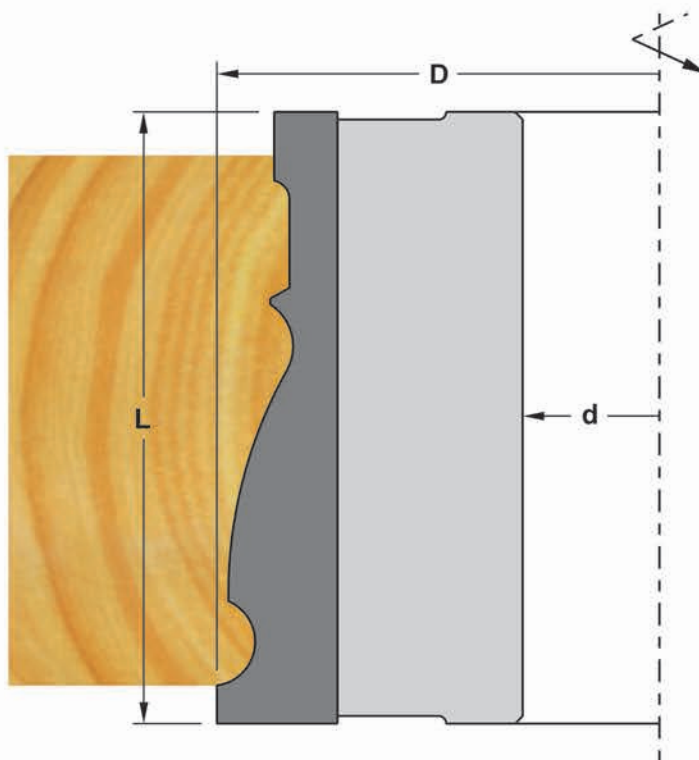

Part No	D	L	Z
2168-080	130	80	4

HM

d50

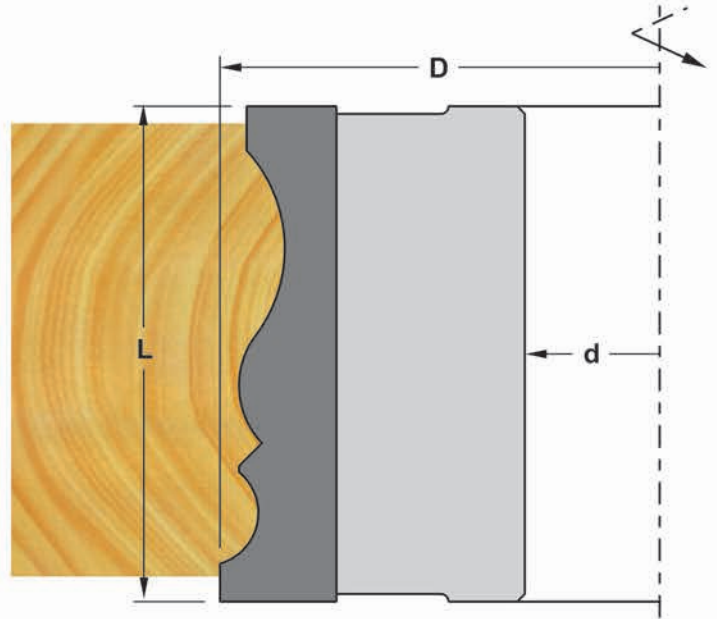

Part No	D	L	Z
2169-065	130	65	4

HM

d50

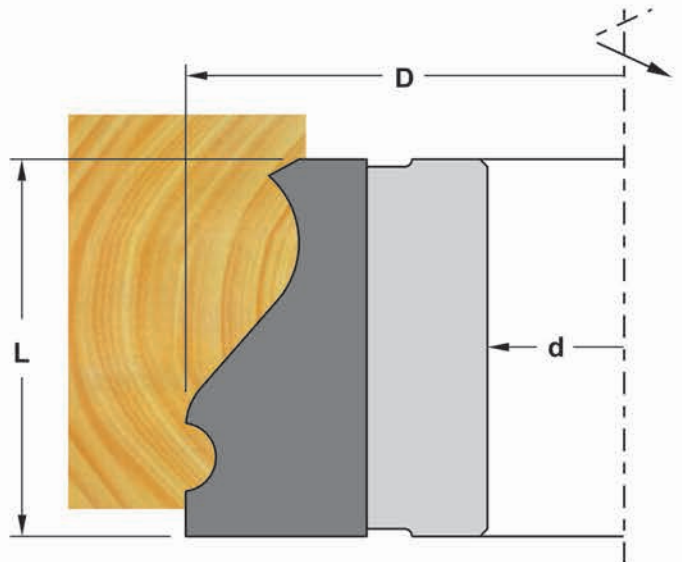

Part No	D	L	Z
2171-050	130	50	4

HM

d50

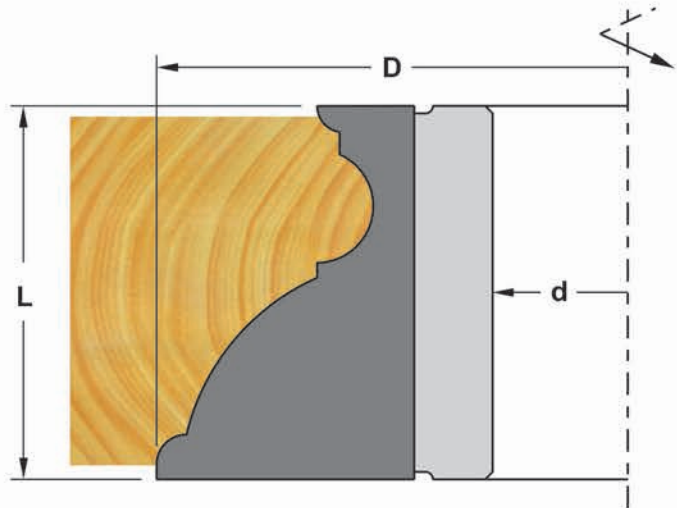

Part No	D	L	Z
2172-050	140	50	4

**HM**

**d50**

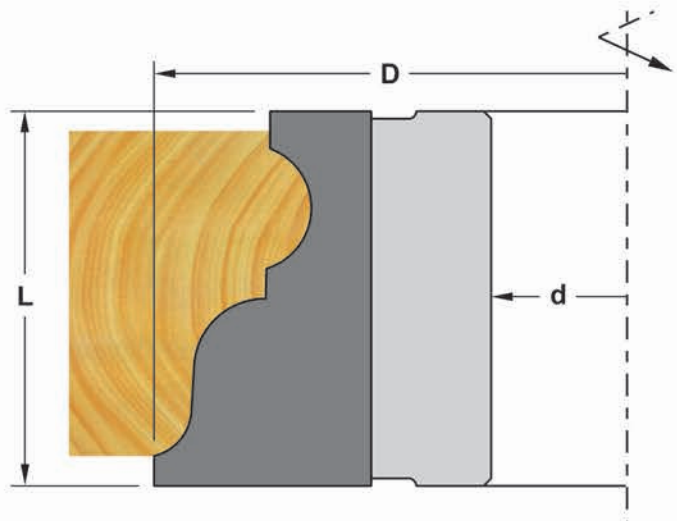

Part No	D	L	Z
2173-050	140	50	4

**HM**

**d50**

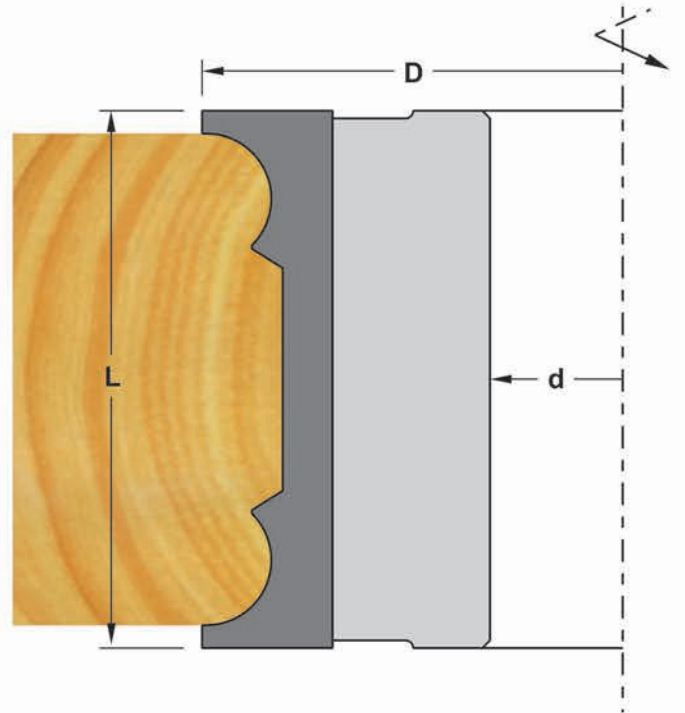

Part No	D	L	Z
2174-070	125	70	4

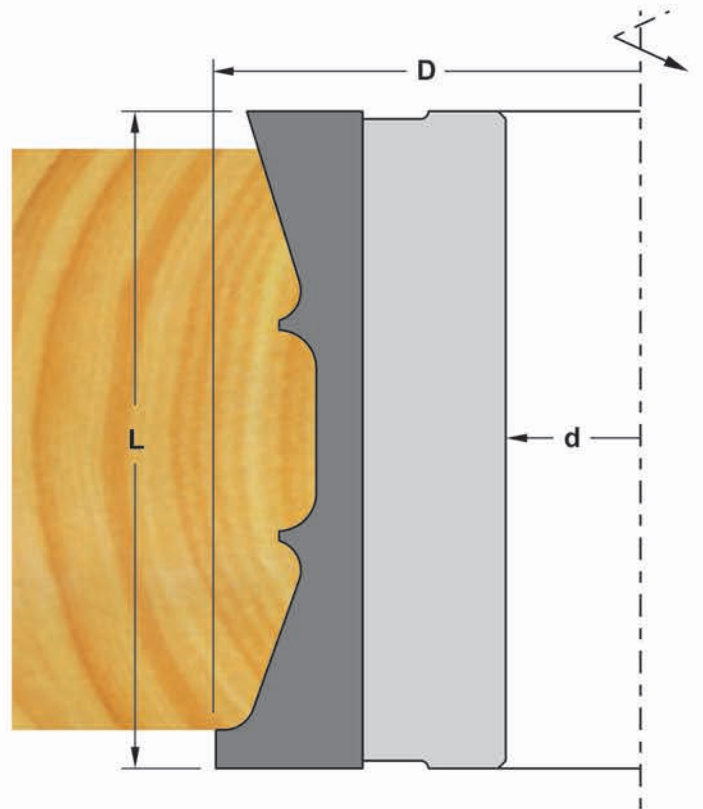

Part No	D	L	Z
2175-085	125	85	4





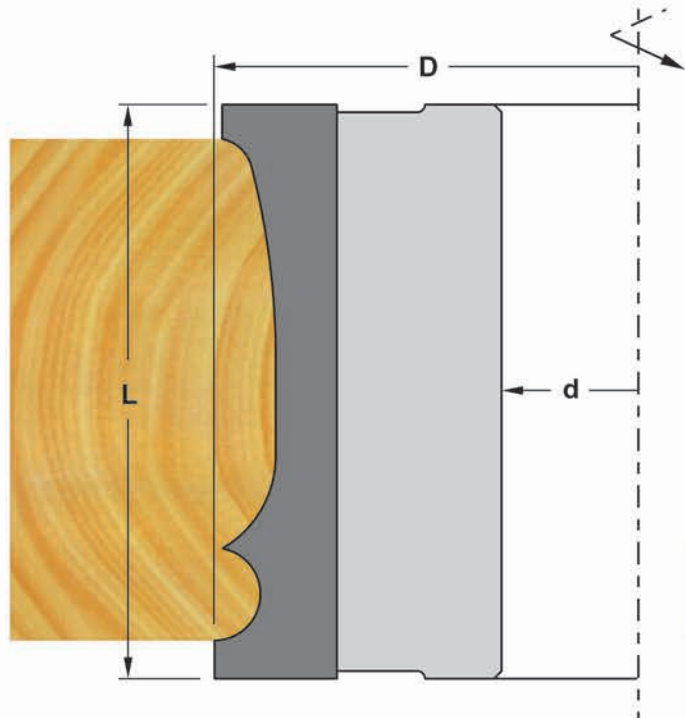

Part No	D	L	Z
2176-075	125	75	4

**HM**

**d50**

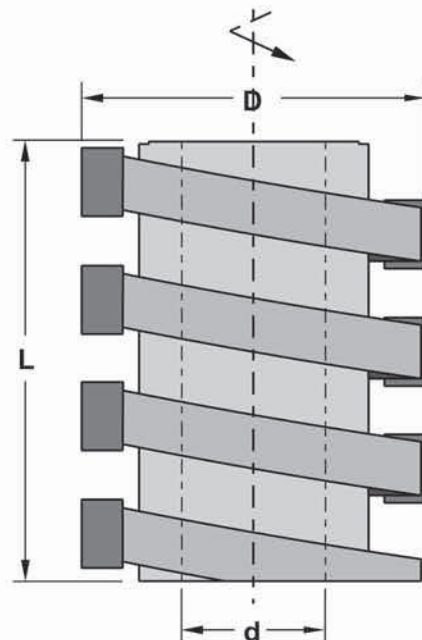
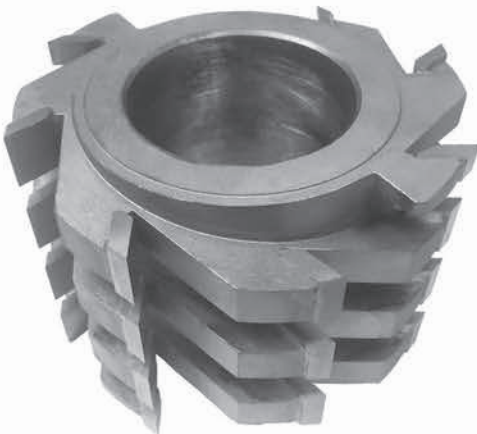

Part No	D	L	Z
2179-065	100	65	30

**HM**

**d50**

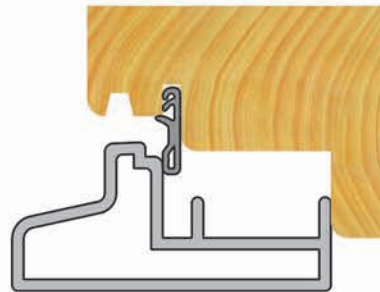
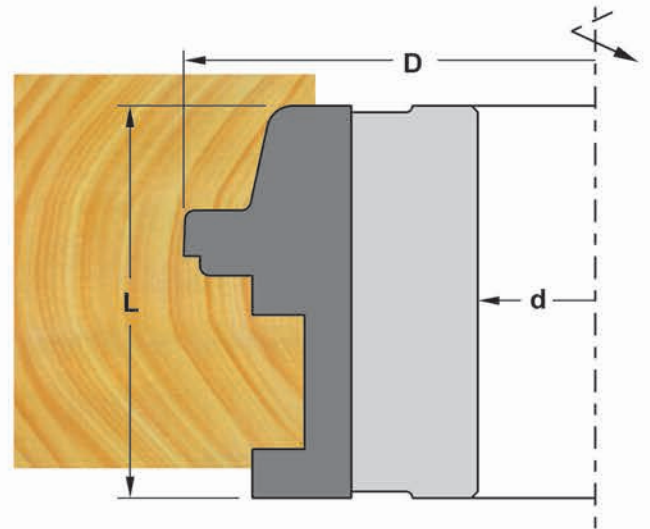
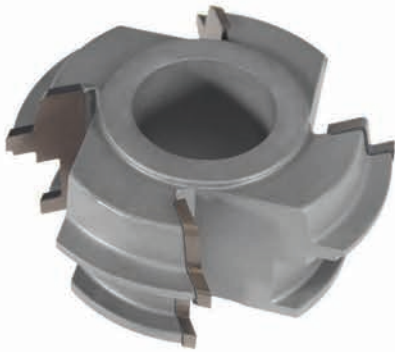

HM d50

Part No	D	L	Z
2178-650	140	60	4

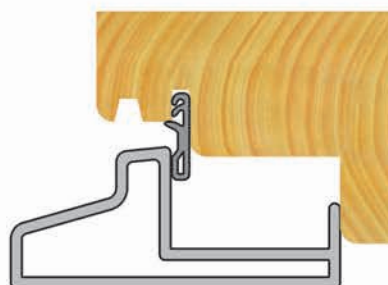
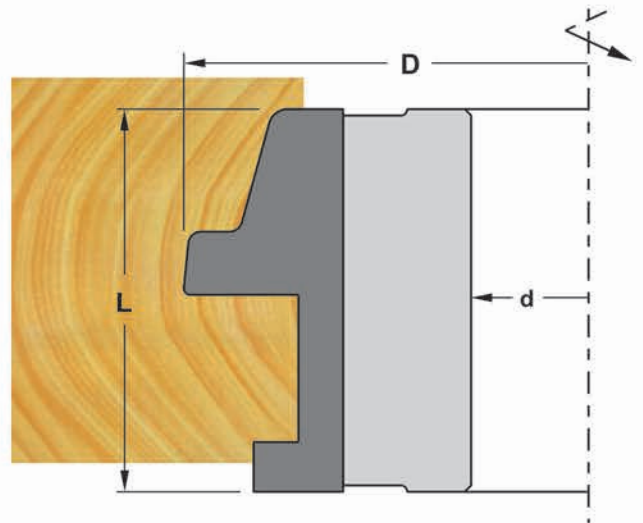

HM d50

Part No	D	L	Z
2178-651	140	60	4

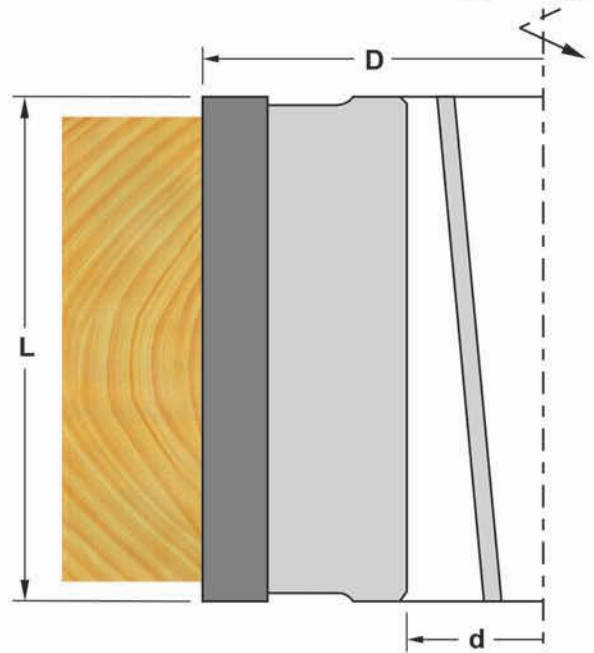

Part No	D	L	d	Z
01-01-100120R	100	120	30	4
01-01-100120L	100	120	30	4

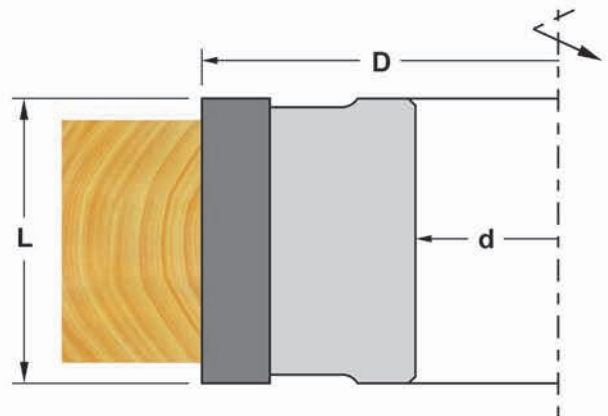

Part No	D	L	d	Z
01-01-12580	125	80	40	4
01-01-12581	125	80	50	4
01-01-125101	125	100	50	4
01-01-125120	125	120	40/50	4

Part No	D	L	d	Z
01-01-125130	125	130	40/50	4



screw



wedge





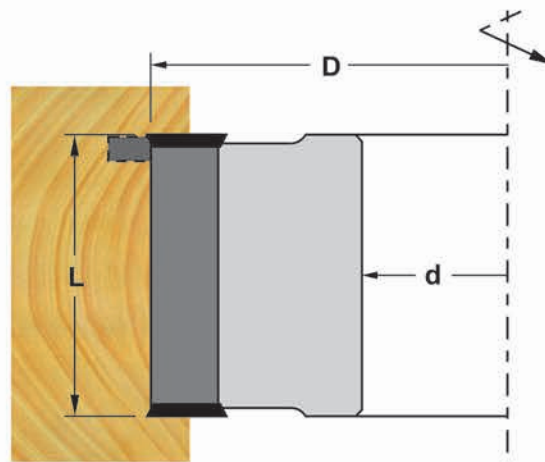







Part No	ΠΕΡΙΓΡΑΦΗ / description	TEM / pcs
SL-L80	80x13x2.2	4
SL-L100	100x13x2.2	4
SL-L120	120x13x2.2	4
SL-L130	130x13x2.2	4
94-02-003	ΒΙΔΑ ΠΙΕΣΕΩΣ M8 L16	12
93-007	ΣΦΥΚΤΗΡΑΣ ΓΙΑ SL-L80	4
93-008	ΣΦΥΚΤΗΡΑΣ ΓΙΑ SL-L100	4
93-006	ΣΦΥΚΤΗΡΑΣ ΓΙΑ SL-L120	4
93-009	ΣΦΥΚΤΗΡΑΣ ΓΙΑ SL-L130	4





Part No	D	L	d	Z	V	I
01-02-10020	100	20	35/50	4	4	---
01-02-10030	100	30	35/50	4	4	---
01-02-10040	100	40	35/50	4	4	---
01-02-10050	100	50	35/50	4	4	---
01-02-10060	100	60	35/50	4	4	---
01-02-12520	125	20	35/50	4	4	---
01-02-12530	125	30	35/50	4	4	---
01-02-12540	125	40	35/50	4	4	---
01-02-12550	125	50	35	4	4	---
01-02-12551	125	50	40	4	4	---
01-02-12552	125	50	50	4	4	2
01-02-12560	125	60	35/50	4	4	---
01-02-16010	160	10	40	4	4	---
01-02-16012	160	12	30	6	4	---

η τιμή της φρέζας δεν περιλαμβάνει τα λάστιχα /  
grooving knives have extra price

Part No	ΠΕΡΙΓΡΑΦΗ / description	TEM / pcs		
	SL-L20	20x12x1.5	4	
	SL-L30	30x12x1.5	4	
	SL-L40	40x12x1.5	4	
	SL-L50	50x12x1.5	4	
	SL-L60	60x12x1.5	4	
	SL-L9.6	9.6x12x1.5	4	
	SL-L11.6	11.6x12x1.5	6	
	94-01-004 (SL-L9.6, SL-L11.6)	ΒΙΔΑ ΚΩΝΙΚΗ M5 L10	4/6	
	94-02-003	ΒΙΔΑ ΠΙΕΣΕΩΣ M8 L16	8	
	V: προχάραξη / spur	SL-L142	ΠΡΟΧΑΡΑΞΗ 14x14x2.0	4
	screw for spur	94-09-001	ΒΙΔΑ ΓΙΑ ΠΡΟΧΑΡΑΞΗ M5 L8	4
	I: λάστιχο / grooving knife	SL-FKB4R	ΛΑΣΤΙΧΟ 34x16x4.0	2
		SL-FKB5R	ΛΑΣΤΙΧΟ 34x16x5.0	2
	screw for grooving knife	94-09-001	ΒΙΔΑ ΓΙΑ ΛΑΣΤΙΧΟ M5 L8	2
	wedge	93-001	ΣΦΥΚΤΗΡΑΣ ΓΙΑ SL-L20	4
		93-002	ΣΦΥΚΤΗΡΑΣ ΓΙΑ SL-L30	4
		93-010	ΣΦΥΚΤΗΡΑΣ ΓΙΑ SL-L40	4
		93-004	ΣΦΥΚΤΗΡΑΣ ΓΙΑ SL-L50	4
		93-011	ΣΦΥΚΤΗΡΑΣ ΓΙΑ SL-L60	4



Radius Cutterhead with Spurs and Grooving Knives



διατίθεται και με βαθύ σκάψιμο

Part No	D	L	d	Z	V	S
01-03-12552	125	50	50	4	2	2

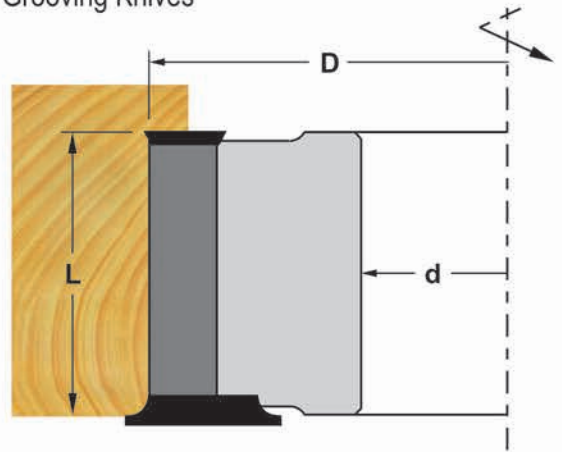

η τιμή της φρέζας δεν περιλαμβάνει τα λάστιχα και τα ράδια /  
grooving knives and radius have extra price

Part No	D	L	d	Z	V	S	I
01-03-12552	125	50	50	4	2	2	2

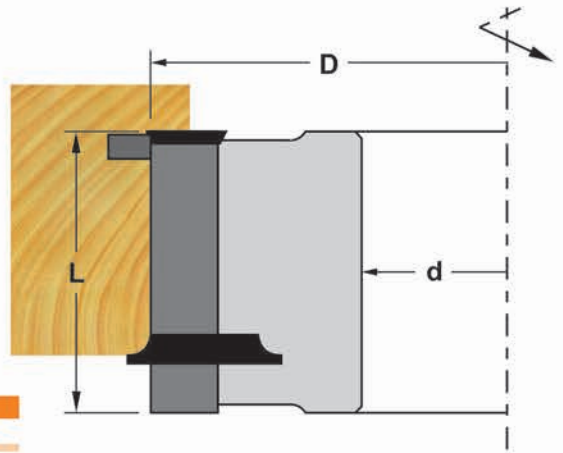

	Part No	ΠΕΡΙΓΡΑΦΗ / description	TEM / pcs
	SL-L50	50x12x1.5	4
 screw	94-02-003	ΒΙΔΑ ΠΙΕΣΕΩΣ M8 L16	8
 <b>V:</b> προχάραξη / spur	SL-L142	ΠΡΟΧΑΡΑΞΗ 14x14x2.0	2
 screw for spur	94-09-001	ΒΙΔΑ ΓΙΑ ΠΡΟΧΑΡΑΞΗ M5 L8	2
 <b>S:</b> ράδιο / radius	SL-FKB-45 SL-FKB-R2 SL-FKB-R3 SL-FKB-R4 SL-FKB-R5	ΦΑΛΤΣΟ 16x22x5.0 - 45° ΡΑΔΙΟ 16x22x5.0 - R2 ΡΑΔΙΟ 16x22x5.0 - R3 ΡΑΔΙΟ 16x22x5.0 - R4 ΡΑΔΙΟ 16x22x5.0 - R5	2 2 2 2 2
 screw for radius	94-07-002	ΒΙΔΑ ΓΙΑ ΡΑΔΙΟ M5 L13	2
 <b>I:</b> λάστιχο / grooving knife	SL-FKB4R SL-FKB5R	ΛΑΣΤΙΧΟ 34x16x4.0 ΛΑΣΤΙΧΟ 34x16x5.0	2 2
 screw for grooving knife	94-09-001	ΒΙΔΑ ΓΙΑ ΛΑΣΤΙΧΟ M5 L8	2
 wedge	93-004	ΣΦΥΚΤΗΡΑΣ ΓΙΑ SL-L50	4

01-06S

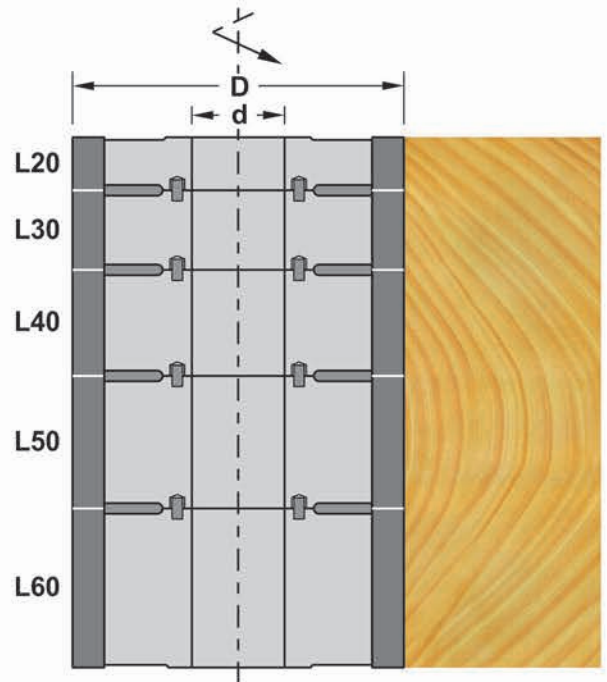

Part No	D	L	d	Z
01-06-10020	100	20	35/40	4
01-06-10030	100	30	35	4
01-06-10031	100	30	40	4
01-06-10040	100	40	35/40	4
01-06-10050	100	50	35/40	4
01-06-10060	100	60	35/40	4
01-06-12520	125	20	35/40	4
01-06-12530	125	30	35	4
01-06-12531	125	30	40	4
01-06-12540	125	40	35	4
01-06-12541	125	40	40	4

Part No	D	L	d	Z
01-06-12550	125	50	35	4
01-06-12551	125	50	40	4
01-06-12560	125	60	35/40	4
01-06-14020	140	20	35/40	4
01-06-14030	140	30	35/40	4
01-06-14040	140	40	35/40	4
01-06-14050	140	50	35	4
01-06-14051	140	50	40	4
01-06-14060	140	60	35/40	4
01-06-16051	160	50	60	6
01-06-16060	160	60	60	6

Part No	D	L	d	Z
01-06-12530S	125	30	40	4
01-06-12550S	125	50	40	4



Part No	ΠΕΡΙΓΡΑΦΗ / description	TEM / pcs
SL-L20	20x12x1.5	4
SL-L30	30x12x1.5	4
SL-L40	40x12x1.5	4
SL-L50	50x12x1.5	4/6
SL-L60	60x12x1.5	4/6



screw

94-02-003 ΒΙΔΑ ΠΙΕΣΕΩΣ M8 L16 4/8

για D140 & D160  
screw for D140 & D160

94-01-007 ΒΙΔΑ ΚΩΝΙΚΗ M6 L12 8/12



wedge

93-001	ΣΦΥΚΤΗΡΑΣ ΓΙΑ SL-L20	4
93-002	ΣΦΥΚΤΗΡΑΣ ΓΙΑ SL-L30	4
93-010	ΣΦΥΚΤΗΡΑΣ ΓΙΑ SL-L40	4
93-004	ΣΦΥΚΤΗΡΑΣ ΓΙΑ SL-L50	4/6
93-011	ΣΦΥΚΤΗΡΑΣ ΓΙΑ SL-L60	4/6

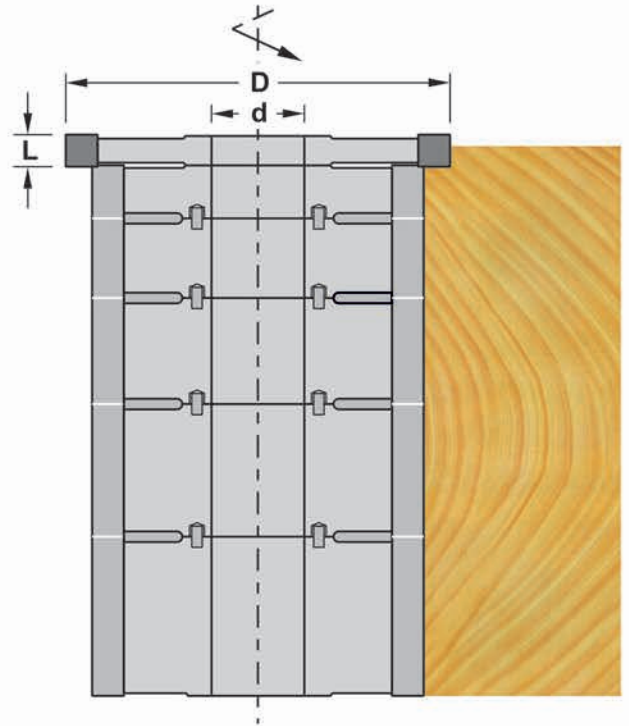
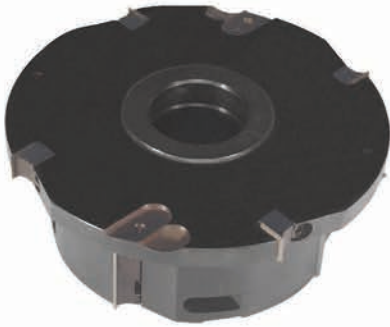

Part No	D	L	d	Z	V
01-07-120122	120	12	40	4	2
01-07-120124	120	12	40	4	4
01-07-145122	145	12	35/40	4	2
01-07-145124	145	12	35/40	4	4
01-07-160122	160	12	35/40	4	2
01-07-160124	160	12	35/40	4	4

*screw*

**V:** προχάραξη / spur

*screw for spur*

*wedge*

Part No	ΠΕΡΙΓΡΑΦΗ / description	ΤΕΜ / pcs
SL-L12	12x12x1.5	4
94-01-004	ΒΙΔΑ ΚΩΝΙΚΗ M5 L10	4
SL-L142	ΠΡΟΧΑΡΑΞΗ 14x14x2.0	2/4
94-09-001	ΒΙΔΑ ΓΙΑ ΠΡΟΧΑΡΑΞΗ M5 L8	2/4
93-013	ΣΦΥΚΤΗΡΑΣ ΓΙΑ SL-L12	4



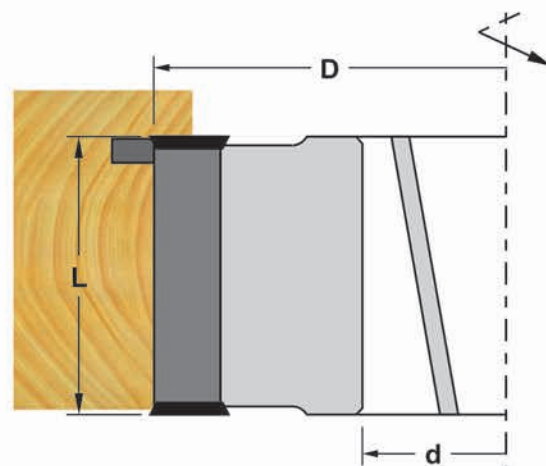

Part No	D	L	d	Z	V	I
01-08-12550	125	50	35	4	2	2
01-08-12551	125	50	50	4	2	2

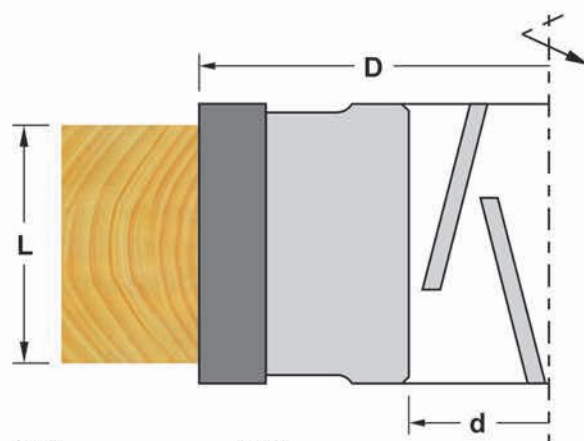

Part No	D	L	d	Z
01-09-12548	125	48	35/50	6
01-09-12556	125	56	35/50	6



screw



V: προχάραξη / spur



screw for spur



I: λάστιχο / grooving knife



screw for grooving knife



wedge

Part No	ΠΕΡΙΓΡΑΦΗ / description	ΤΕΜ / pcs
SL-L25	25x12x1.5	6
SL-L30	30x12x1.5	6
SL-L50	50x12x1.5	4
94-01-007	ΒΙΔΑ ΚΩΝΙΚΗ M6 L12	6/8
SL-L142	ΠΡΟΧΑΡΑΞΗ 14x14x2.0	2
94-09-001	ΒΙΔΑ ΓΙΑ ΠΡΟΧΑΡΑΞΗ M5 L8	2
SL-FKB4R	ΛΑΣΤΙΧΟ 34x16x4.0	2
SL-FKB5R	ΛΑΣΤΙΧΟ 34x16x5.0	2
94-09-001	ΒΙΔΑ ΓΙΑ ΛΑΣΤΙΧΟ M5 L8	2
93-004	ΣΦΥΚΤΗΡΑΣ ΓΙΑ SL-L50	4
93-002	ΣΦΥΚΤΗΡΑΣ ΓΙΑ SL-L30	6



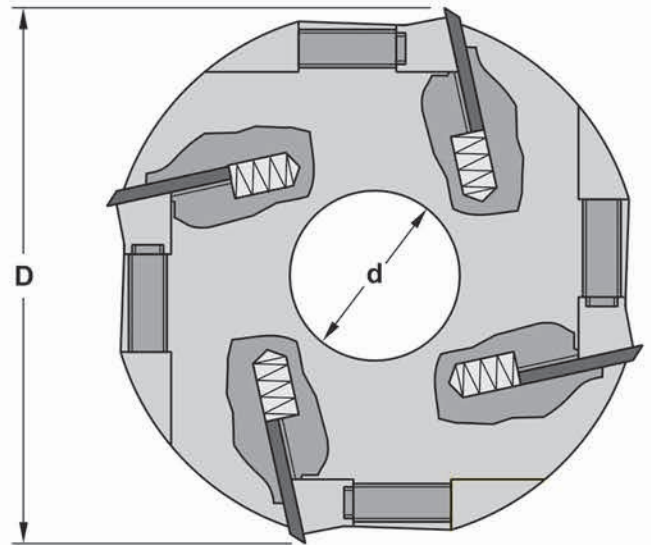

Part No	D	L	d	Z
02-01-125100	125	100	40	4
02-01-125110	125	110	40	4
02-01-125120	125	120	40	4
02-01-125130	125	130	40	4
02-01-125150	125	150	40	4
02-01-125160	125	160	40	4
02-01-125180	125	180	40	4
02-01-125200	125	200	40	4
02-01-125220	125	220	40	4
02-01-AL	ΟΔΗΓΟΣ SET ΠΑΤΟΥΡΑΣ AL			

η τιμή της φρέζας δεν περιλαμβάνει τα μαχαίρια /  
knives have extra price



screw



wedge

Part No	ΠΕΡΙΓΡΑΦΗ / description	ΤΕΜ / pcs
SP	HSS 18% ΒΙΝΤΙΑ	
3030-103	3230-103 3430-103 100x30x3.0	4
3030-113	3230-113 3430-113 110x30x3.0	4
3030-123	3230-123 3430-123 120x30x3.0	4
3030-133	3230-133 3430-133 130x30x3.0	4
3030-153	3230-153 3430-153 150x30x3.0	4
3030-163	3230-163 3430-163 160x30x3.0	4
3030-183	3230-183 3430-183 180x30x3.0	4
3030-203	3230-203 3430-203 200x30x3.0	4
3030-223	3230-223 3430-223 220x30x3.0	4
94-02-003	ΒΙΔΑ ΠΙΕΣΕΩΣ M8 L16	L100/110=12 L120/130=16 L150 έως L220=20
93-020	ΣΦΥΚΤΗΡΑΣ ΓΙΑ MAX L100	4
93-021	ΣΦΥΚΤΗΡΑΣ ΓΙΑ MAX L110	4
93-022	ΣΦΥΚΤΗΡΑΣ ΓΙΑ MAX L120	4
93-023	ΣΦΥΚΤΗΡΑΣ ΓΙΑ MAX L130	4
93-024	ΣΦΥΚΤΗΡΑΣ ΓΙΑ MAX L150	4
93-025	ΣΦΥΚΤΗΡΑΣ ΓΙΑ MAX L160	4
93-026	ΣΦΥΚΤΗΡΑΣ ΓΙΑ MAX L180	4
93-027	ΣΦΥΚΤΗΡΑΣ ΓΙΑ MAX L200	4
93-028	ΣΦΥΚΤΗΡΑΣ ΓΙΑ MAX L220	4

## Planing Head with Reversible Knives

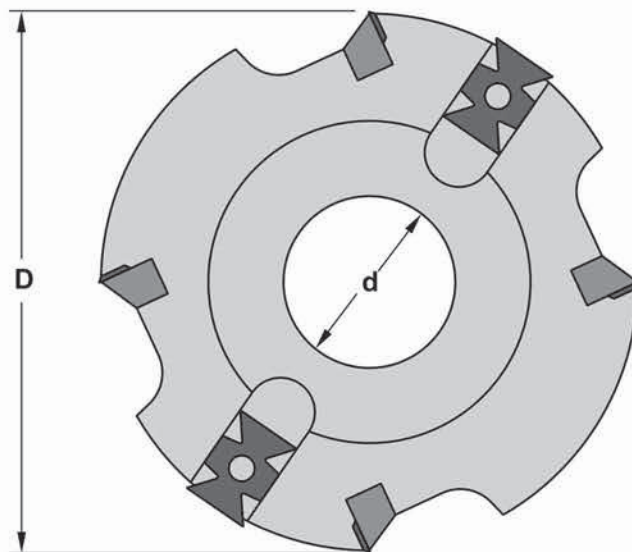

Part No	D	L	d	Z	S
02-02-125120	125	120	40	4	4
02-02-125150	125	150	40	4	4
02-02-125160	125	160	40	4	4
02-02-125180	125	180	40	4	---
02-02-125200	125	200	40	4	---
02-02-125220	125	220	40	4	---

η τιμή της φρέζας δεν περιλαμβάνει τα ράδια /  
radius have extra price



Part No	ΠΕΡΙΓΡΑΦΗ / description	ΤΕΜ / pcs
SL-L50	50x12x1.5	4
SL-L60	60x12x1.5	4
94-01-012	ΒΙΔΑ ΚΩΝΙΚΗ M8 L12	L120=16 L150 εώς L180=24 L200/220=32
SL-FKB-45	ΦΑΛΤΣΟ 16x22x5.0 - 45°	4
SL-FKB-R2	ΡΑΔΙΟ 16x22x5.0 - R2	4
SL-FKB-R3	ΡΑΔΙΟ 16x22x5.0 - R3	4
SL-FKB-R4	ΡΑΔΙΟ 16x22x5.0 - R4	4
SL-FKB-R5	ΡΑΔΙΟ 16x22x5.0 - R5	4
94-07-002	ΒΙΔΑ ΓΙΑ ΡΑΔΙΟ M5 L13	4
93-004	ΣΦΥΚΤΗΡΑΣ ΓΙΑ SL-L50	L120=8
93-011	ΣΦΥΚΤΗΡΑΣ ΓΙΑ SL-L60	L150 εώς L180=12 L200/220=16



screw



S: ράδιο / radius

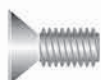

screw for radius



wedge

L120=2xSL-L60  
L150=3xSL-L50

L160=2xSL-L50, 1xSL-L60  
L180=3xSL-L60

L200=4xSL-L50  
L220=2xSL-L60, 2xSL-L50



2197-394



2197-396



2197-397

Part No	D	L	d	Z
03-01-11740	117	40	50	2
2196-394	ΚΑΣΕΤΙΝΑ / set			
2196-396	ΚΑΣΕΤΙΝΑ / set			
2196-397	ΚΑΣΕΤΙΝΑ / set			
2197-394	ΚΑΣΕΤΙΝΑ ΚΟΜΠΛΕ / full set			
2197-396	ΚΑΣΕΤΙΝΑ ΚΟΜΠΛΕ / full set			
2197-397	ΚΑΣΕΤΙΝΑ ΚΟΜΠΛΕ / full set			



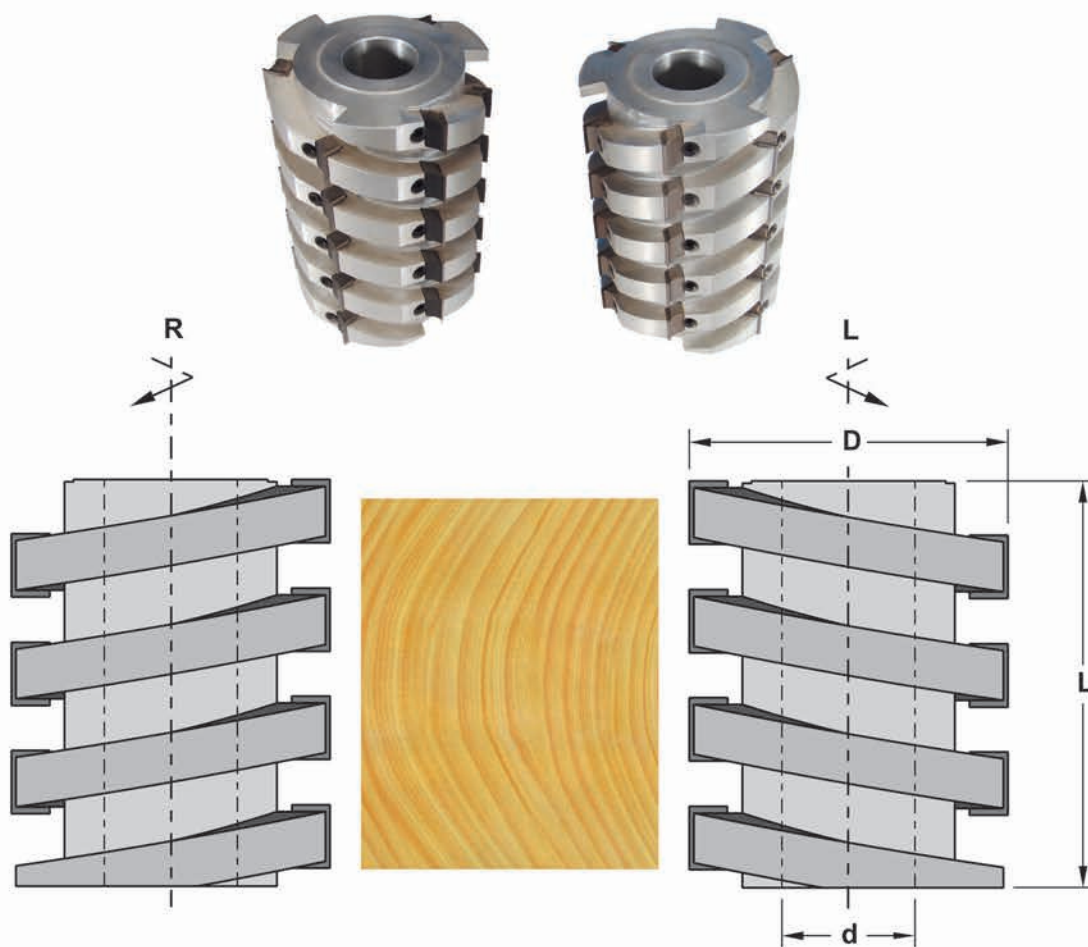

Part No	D	L	d	Z
05-01-10060R	100	60	40	18
05-01-10060L	100	60	40	18
05-01-10080R	100	80	40	15
05-01-10080L	100	80	40	15
05-01-100100R	100	100	40	18
05-01-100100L	100	100	40	18
05-01-100120R	100	120	40	21
05-01-100120L	100	120	40	21

Part No	D	L	d	Z
05-01-12560R	125	60	40	18
05-01-12560L	125	60	40	18
05-01-12580R	125	80	40	15
05-01-12580L	125	80	40	15
05-01-125100R	125	100	40	18
05-01-125100L	125	100	40	18
05-01-125120R	125	120	40	21
05-01-125120L	125	120	40	21
05-01-125180R	125	180	40	30
05-01-125180L	125	180	40	30



για **SL-L20**  
screw for **SL-L20**



για **SL-L12**  
screw for **SL-L12**



wedge

Part No	ΠΕΡΙΓΡΑΦΗ / description	TEM / pcs
SL-L12 SL-L20	12x12x1.5 20x12x1.5	
94-01-007	ΒΙΔΑ ΚΩΝΙΚΗ M6 L12	L80=15 L100=18 L120=21 L180=30
94-01-004	ΒΙΔΑ ΚΩΝΙΚΗ M5 L10	18
93-001R 93-001L	ΣΦΥΚΤΗΡΑΣ ΓΙΑ SL-L20 ΔΕ ΣΦΥΚΤΗΡΑΣ ΓΙΑ SL-L20 ΑΡ	L80=15 L100=18 L120=21 L180=30
93-013R 93-013L	ΣΦΥΚΤΗΡΑΣ ΓΙΑ SL-L12 ΔΕ ΣΦΥΚΤΗΡΑΣ ΓΙΑ SL-L12 ΑΡ	18 18

για L=60 SL-L12, για τα υπόλοιπα SL-L20

for L=60 SL-L12, for the rest sizes SL-L20



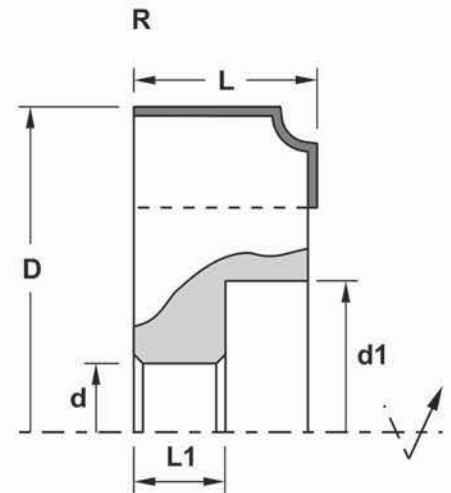

Part No	D	L	d	Z	d1	L1	ΜΗΧΑΝΗ / machine
06-01-7020R	70	20	15	6	34	12	---
06-01-7020L	70	20	15	6	34	12	---
06-01-8020R	80	20	14	6	44	12	STEFANI
06-01-8020L	80	20	14	6	44	12	STEFANI
06-01-8030R	80	30	16	6	44	12.5	HOLZ-HER
06-01-8030L	80	30	16	6	44	12.5	HOLZ-HER

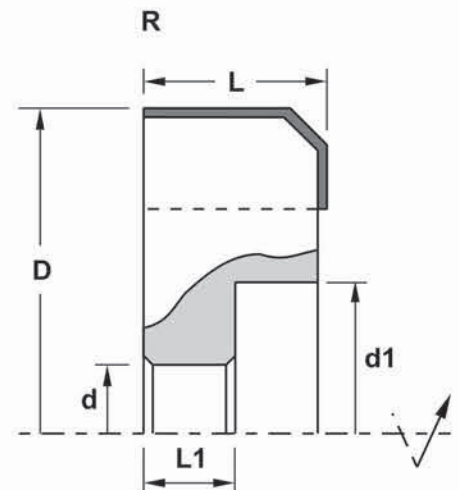

Part No	D	L	d	Z	d1	L1	ΜΗΧΑΝΗ / machine
06-02-7020R	70	20	15	6	34	12	---
06-02-7020L	70	20	15	6	34	12	---
06-02-8030R	80	30	16	6	44	12.5	HOLZ-HER
06-02-8030L	80	30	16	6	44	12.5	HOLZ-HER

**SL-L30BR3L**

**SL-L20BR3L**

**SL-L30BR3R**

**SL-L20BR3R**

**SL-L30CL**

**SL-L20CL**

**SL-L30CR**

**SL-L20CR**

*screw*

*wedge*

Part No	ΠΕΡΙΓΡΑΦΗ / description	TEM / pcs
SL-L20BR3R	20x12x1.5 - R3	6
SL-L20BR3L	20x12x1.5 - R3	6
SL-L30BR3R	30x12x1.5 - R3	6
SL-L30BR3L	30x12x1.5 - R3	6
SL-L20CR	20x12x1.5 - 45°	6
SL-L20CL	20x12x1.5 - 45°	6
SL-L30CR	30x12x1.5 - 45°	6
SL-L30CL	30x12x1.5 - 45°	6
94-02-001	ΒΙΔΑ ΠΙΕΣΕΩΣ M6 L12	L20=6 L30=12
93-001R	ΣΦΥΚΤΗΡΑΣ ΓΙΑ SL-L20 ΔΕ	6
93-001L	ΣΦΥΚΤΗΡΑΣ ΓΙΑ SL-L20 ΑΡ	6
93-002R	ΣΦΥΚΤΗΡΑΣ ΓΙΑ SL-L30 ΔΕ	6
93-002L	ΣΦΥΚΤΗΡΑΣ ΓΙΑ SL-L30 ΑΡ	6

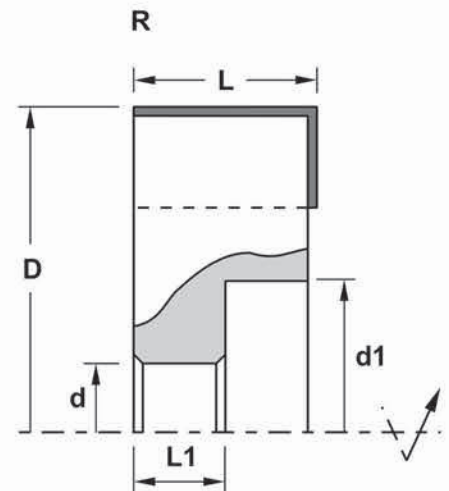

Part No	D	L	d	Z	d1	L1	ΜΗΧΑΝΗ / machine
06-03-7020R	70	20	15	6	34	12	---
06-03-7020L	70	20	15	6	34	12	---
06-03-8020R	80	20	14	6	44	12	STEFANI
06-03-8020L	80	20	14	6	44	12	STEFANI
06-03-8030R	80	30	16	6	44	12.5	---
06-03-8030L	80	30	16	6	44	12.5	---

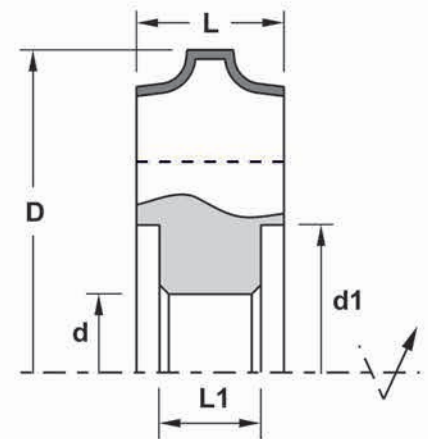

Part No	D	L	d	Z	d1	L1	ΜΗΧΑΝΗ / machine
06-04-6816	68.5	16	16	3	31.5	11	---
06-04-7316	73	16	16	3	30.5	11	HOMAG
06-04-7320	73	16	20	3	30.5	11	HOLZ-HER
06-04-8214	82	16	14	3	30.5	11	STEFANI
06-04-8216	82	16	16	3	37.5	11	STEFANI
06-04-8220	82	16	20	3	37.5	11	IMA
06-04-9532	95	16	32	6	49.5	10	EGURKO
06-04-9516	95	16	16	6	49.5	10	---



Part No	ΠΕΡΙΓΡΑΦΗ / description	TEM / pcs
SL-L20	20x12x1.5	6
SL-L30	30x12x1.5	6



SL-L15P	16x15x1.5 - R3	3
SL-L17P	16x17.5x2.0 - R3	3/6
SL-L17P1	16x17.5x2.0 - R3	3/6
SL-L17P2	16x17.5x2.0 - R3	3/6



screw

94-02-001	ΒΙΔΑ ΠΙΕΣΕΩΣ M6 L12	L20=6 L30=12 L16 Z3=3
-----------	---------------------	-----------------------------



screw

94-01-007	ΒΙΔΑ ΚΩΝΙΚΗ M6 L12	L16 Z6=6
-----------	--------------------	----------



wedge

93-001R	ΣΦΥΚΤΗΡΑΣ ΓΙΑ SL-L20 ΔΕΞ	6
93-001L	ΣΦΥΚΤΗΡΑΣ ΓΙΑ SL-L20 ΑΠ	6
93-002R	ΣΦΥΚΤΗΡΑΣ ΓΙΑ SL-L30 ΔΕΞ	6
93-002L	ΣΦΥΚΤΗΡΑΣ ΓΙΑ SL-L30 ΑΠ	6
93-015	ΣΦΥΚΤΗΡΑΣ ΓΙΑ SL-L15P	3
93-016	ΣΦΥΚΤΗΡΑΣ ΓΙΑ SL-L17P	3/6

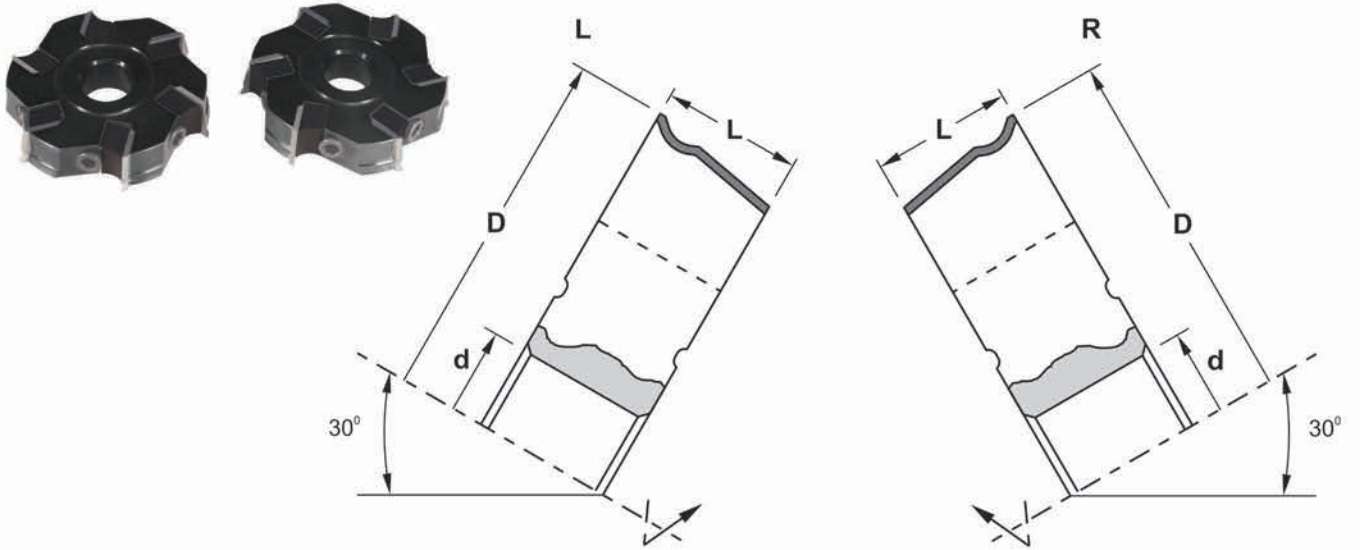

Part No	D	L	d	Z	d1	L1	ΜΗΧΑΝΗ / machine
06-05-8316R	83	16	20	6	---	---	ACOSTA
06-05-8316L	83	16	20	6	---	---	ACOSTA

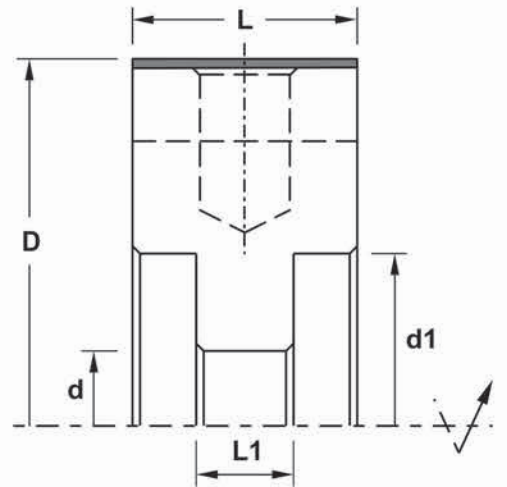
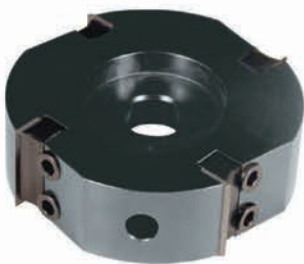

Part No	D	L	d	Z	d1	L1	ΜΗΧΑΝΗ / machine
06-06-10030	100	30	20	4	46	12.5	STEFANI



SL-L19.5PR



SL-L19.5PL



SL-L30



screw



wedge

Part No	ΠΕΡΙΓΡΑΦΗ / description	TEM / pcs
SL-L19.5PR	16x19.5x2.0 - R3	6
SL-L19.5PL	16x19.5x2.0 - R3	6
SL-L30	30x12x1.5	4
94-01-007	ΒΙΔΑ ΚΩΝΙΚΗ M6 L12	L16=6 L30=8
93-002	ΣΦΥΚΤΗΡΑΣ ΓΙΑ SL-L30	4





Part No	D	L	d	Z
07-01-FA	200	60	50	2+2
07-01-1FA	200	60	50	2+2

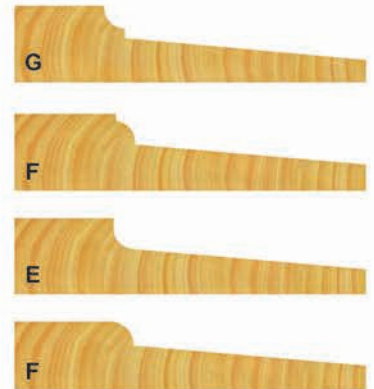
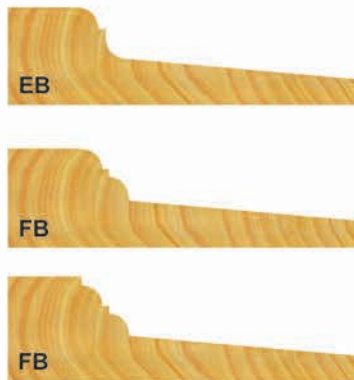
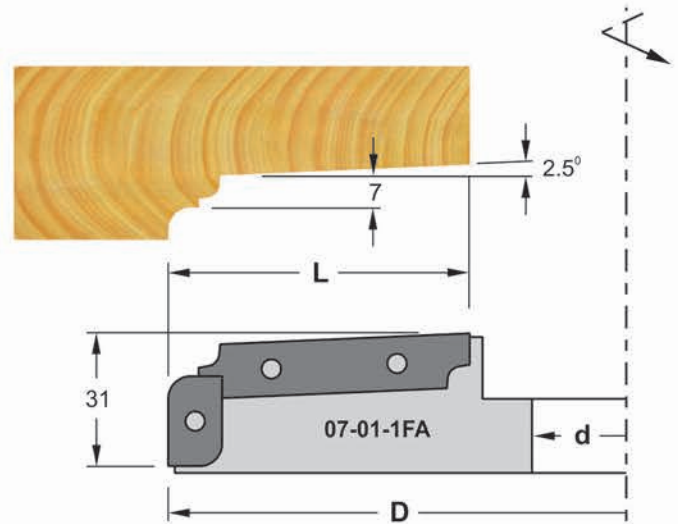
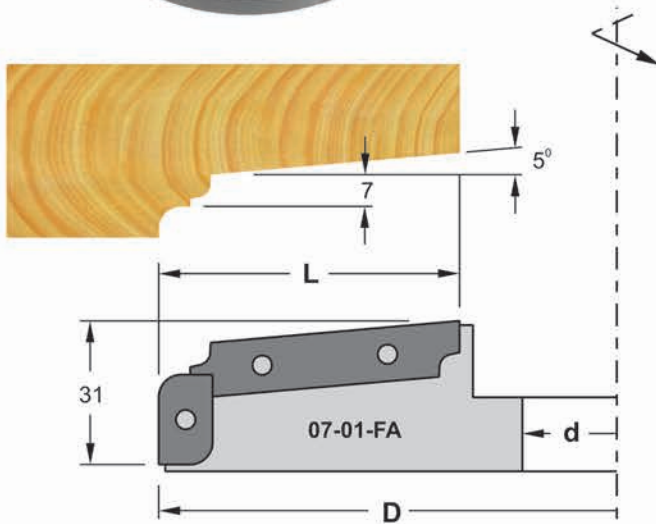

Part No	ΠΕΡΙΓΡΑΦΗ / description	TEM / pcs
SL-L60GR	60x12x1.5	2
SL-L60FR	60x12x1.5	2
SL-L60ER	60x12x1.5	2
SL-L20BR5R	20x12x1.5 - R5	2
SL-L20AR5R	20x12x1.5 - R5	2
94-01-007 94-01-012	ΒΙΔΑ ΚΩΝΙΚΗ M6 L12 ΒΙΔΑ ΚΩΝΙΚΗ M8 L12	L20=2 L60=4
93-001 93-011	ΣΦΥΚΤΗΡΑΣ ΓΙΑ SL-L20 ΣΦΥΚΤΗΡΑΣ ΓΙΑ SL-L60	2 2



screw



wedge



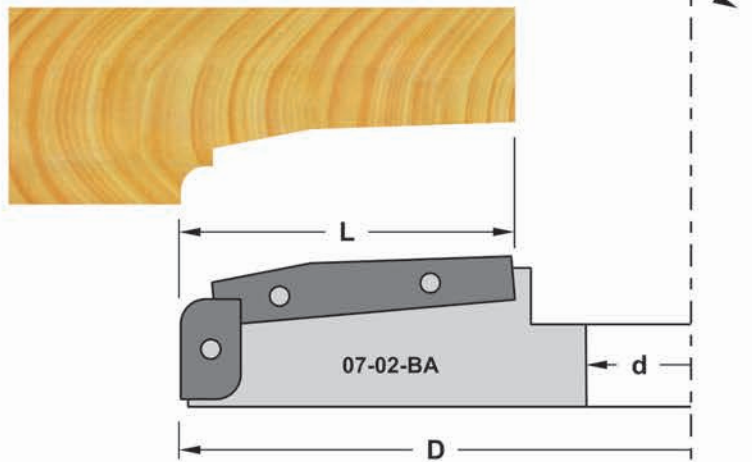
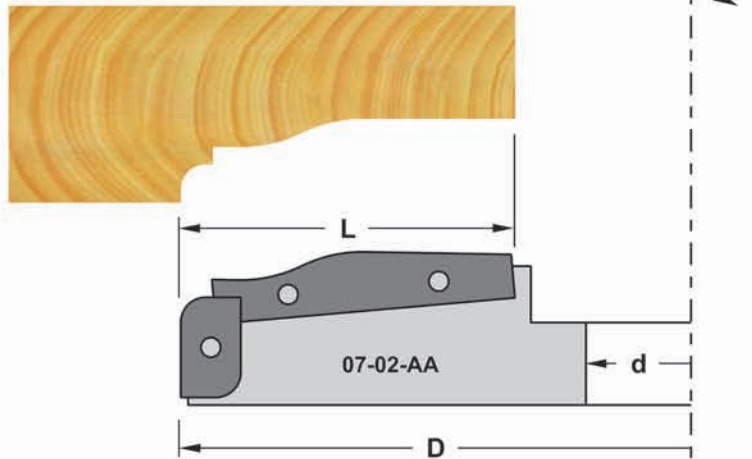

Part No	D	L	d	Z
07-02-AA	200	60	50	2+2
07-02-BA	200	60	50	2+2



screw



wedge

Part No	ΠΕΡΙΓΡΑΦΗ / description	TEM / pcs
SL-L60AR	60x12x1.5	2
SL-L60BR	60x12x1.5	2
SL-L20AR5R	20x12x1.5 - R5	2
94-01-007	ΒΙΔΑ ΚΩΝΙΚΗ M6 L12	L20=2
94-01-012	ΒΙΔΑ ΚΩΝΙΚΗ M8 L12	L60=4
93-001	ΣΦΥΚΤΗΡΑΣ ΓΙΑ SL-L20	2
93-011	ΣΦΥΚΤΗΡΑΣ ΓΙΑ SL-L60	2

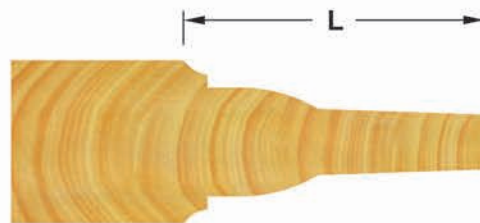
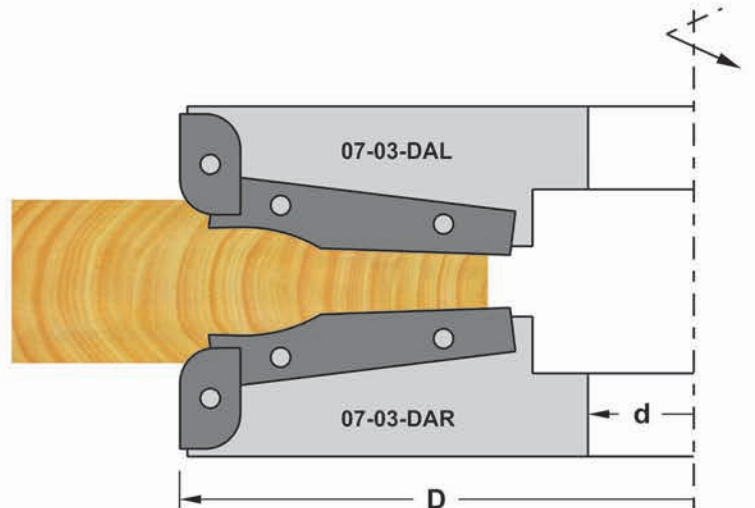

Part No	D	L	d	Z
07-03-DAR	200	60	50	2+2
07-03-DAL	200	60	50	2+2

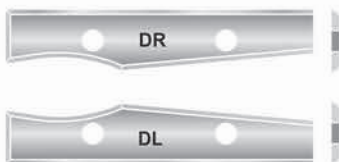

Part No	ΠΕΡΙΓΡΑΦΗ / description	TEM / pcs
SL-L60DR SL-L60DL	60x12x1.5 60x12x1.5	2 2
SL-L20AR7R SL-L20AR7L	20x12x1.5 - R7 20x12x1.5 - R7	2 2
94-01-007 94-01-012	ΒΙΔΑ ΚΩΝΙΚΗ M6 L12 ΒΙΔΑ ΚΩΝΙΚΗ M8 L12	L20=2 L60=4
	wedge	

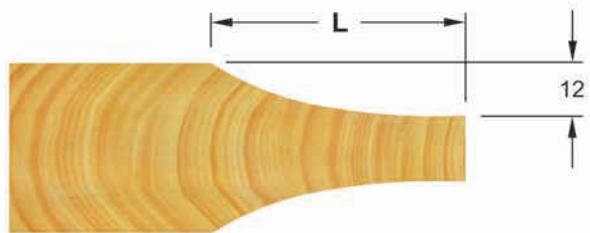
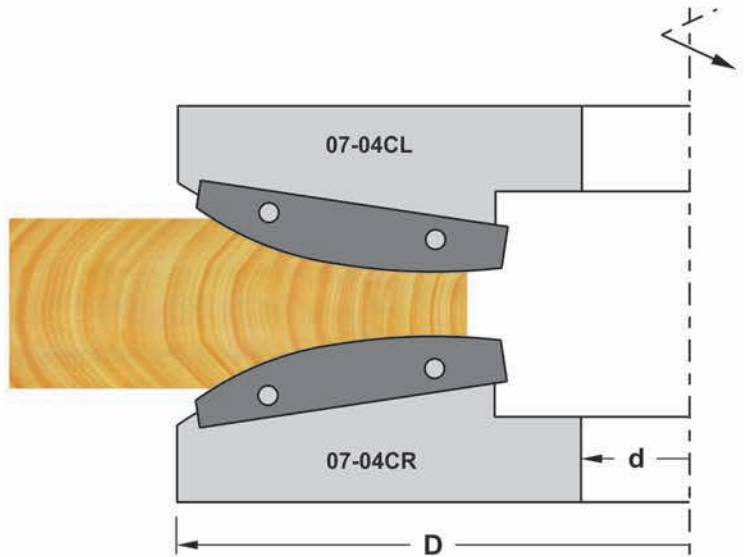

Part No	D	L	d	Z
07-04-CR	190	60	50	3
07-04-CL	190	60	50	3



screw



wedge

Part No	ΠΕΡΙΓΡΑΦΗ / description	TEM / pcs
SL-L60CR	60x12x1.5	3
SL-L60CL	60x12x1.5	3
94-01-012	ΒΙΔΑ ΚΩΝΙΚΗ M8 L12	6

Counter Profile Cutterhead

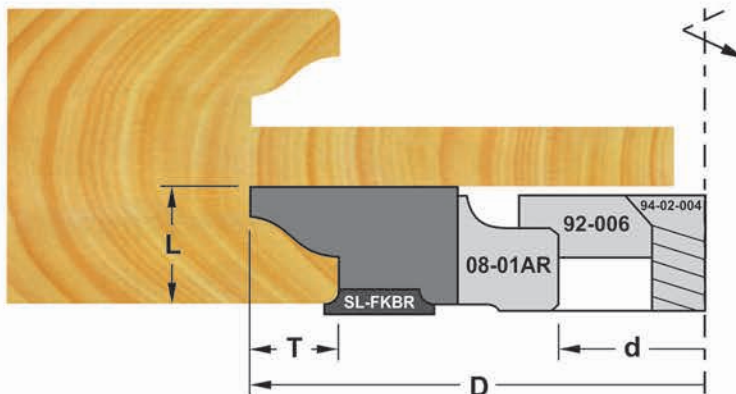
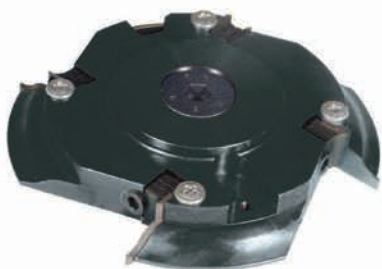

η τιμή της φρέζας δεν περιλαμβάνει βίδα-καπελάκι-κλειδί /  
spanner, screw and reducing bushing have extra price

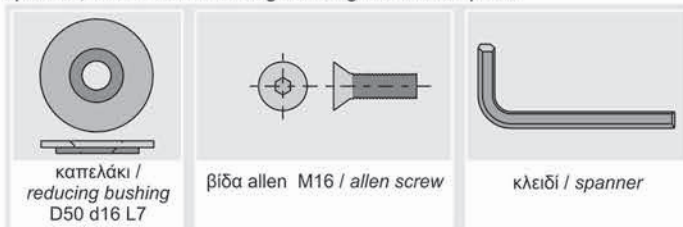

Part No	D	L	d	Z	T	S
08-01-AR	154	20	50	4	15	2
2111-K						ΚΛΕΙΔΙ / spanner
92-006						ΚΑΠΕΛΑΚΙ / reducing bushing
B-02-004						ΒΙΔΑ ALLEN M16 / allen screw

η τιμή της φρέζας δεν περιλαμβάνει τα ράδια /  
radius have extra price

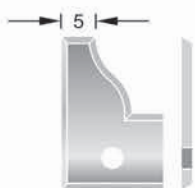

screw

Part No	ΠΕΡΙΓΡΑΦΗ / description	TEM / pcs
SL-L102-21R	20x30x2.0 - T15	4
94-01-009	ΒΙΔΑ ΚΩΝΙΚΗ M6 L16	4
SL-FKB-45	ΦΑΛΤΣΟ 16x22x5.0 - 45°	2
SL-FKB-R2	ΡΑΔΙΟ 16x22x5.0 - R2	2
SL-FKB-R3	ΡΑΔΙΟ 16x22x5.0 - R3	2
SL-FKB-R4	ΡΑΔΙΟ 16x22x5.0 - R4	2
SL-FKB-R5	ΡΑΔΙΟ 16x22x5.0 - R5	2
94-07-002	ΒΙΔΑ ΓΙΑ ΡΑΔΙΟ M5 L13	2



S: ράδιο / radius



screw for radius



wedge



Counter Profile Cutterhead

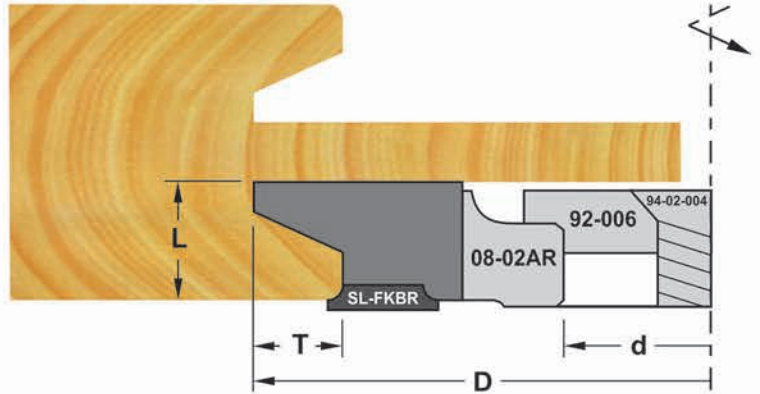

η τιμή της φρέζας δεν περιλαμβάνει βίδα-καπελάκι-κλειδί /  
spanner, screw and reducing bushing have extra price

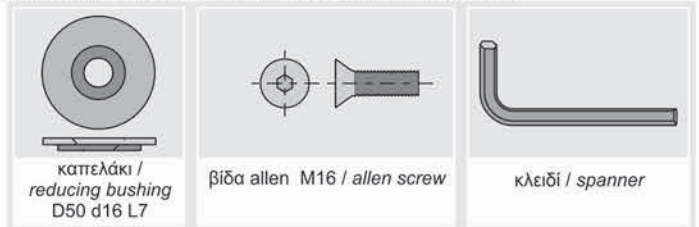

Part No	D	L	d	Z	T	S
08-02-AR	154	20	50	4	15	2
2111-K	ΚΛΕΙΔΙ / spanner					
92-006	ΚΑΠΕΛΑΚΙ / reducing bushing					
B-02-004	ΒΙΔΑ ALLEN M16 / allen screw					

η τιμή της φρέζας δεν περιλαμβάνει τα ράδια /  
radius have extra price

Part No	ΠΕΡΙΓΡΑΦΗ / description	TEM / pcs
SL-L101-22R	20x30x2.0 - T15	4
94-01-009	ΒΙΔΑ ΚΩΝΙΚΗ M6 L16	4
SL-FKB-45	ΦΑΛΤΣΟ 16x22x5.0 - 45°	2
SL-FKB-R2	ΡΑΔΙΟ 16x22x5.0 - R2	2
SL-FKB-R3	ΡΑΔΙΟ 16x22x5.0 - R3	2
SL-FKB-R4	ΡΑΔΙΟ 16x22x5.0 - R4	2
SL-FKB-R5	ΡΑΔΙΟ 16x22x5.0 - R5	2
94-07-002	ΒΙΔΑ ΓΙΑ ΡΑΔΙΟ M5 L13	2
	wedge	

Profile Cutterhead Set For Internal Doors

ΡΟΥΛΕΜΑΝ / bearing

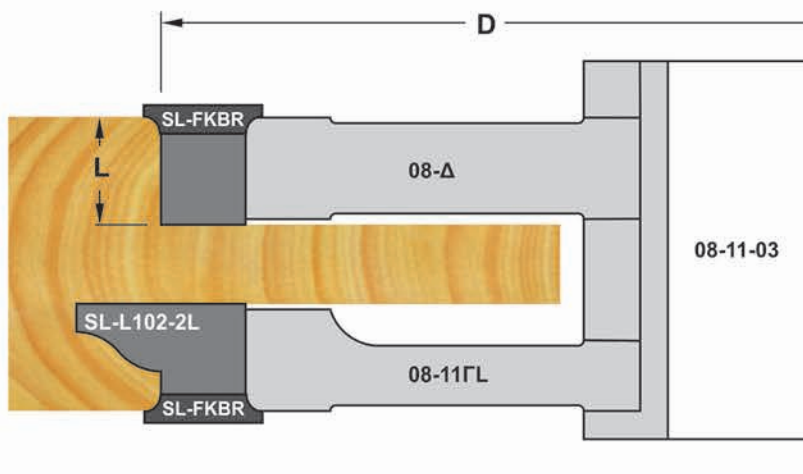
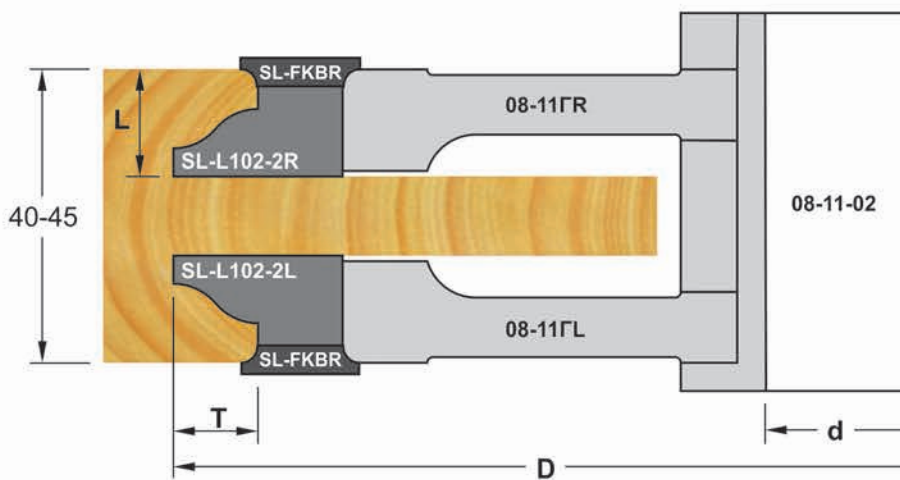
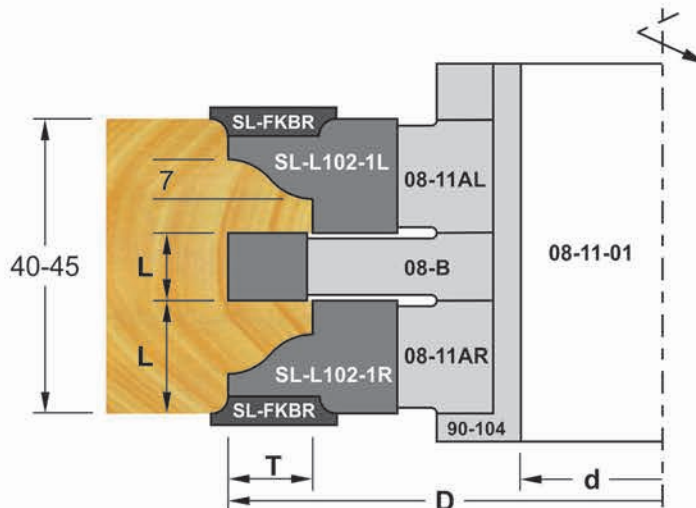
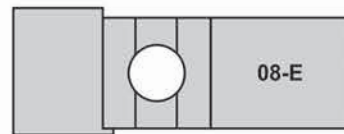

**Profile Cutterhead Set For Internal Doors**

Part No	D	L	d	Z	T	V	S
08-11-01	154	ΣΕΤ ΤΖΑΜΙΛΙΚΙΟΥ ΠΕΡΙΣΠΩΜΕΝΗ / cutterhead set					
08-11-02	300	ΣΕΤ ΞΕΜΟΣΣΑΡ. ΠΕΡΙΣΠΩΜΕΝΗ / cutterhead set					
08-11-03	300/270	ΣΕΤ ΞΕΜΟΣΣΑΡ. ΠΕΡΙΣΠΩΜΕΝΗ / cutterhead set					
08-08B	154	8	60	4	---	4	---
08-10B	154	10	60	4	---	4	---
08-12B	154	12	60	4	---	4	---
08-14B	154	14	60	4	---	4	---
08-E	134	25	60	ΡΟΥΛΕΜΑΝ / bearing			
90-104	60	105	35/50	ΑΞΟΝΑΣ-ΡΟΔΕΛΕΣ / spacing rings			
08-50Δ	270	20	50	4	---	4	2
08-60Δ	270	20	60	4	---	4	2
08-11-AR	154	20	60	4	15	---	2
08-11-AL	154	20	60	4	15	---	2
08-11-ΓΡ50	300	20	50	4	15	2	2
08-11-ΓΛ50	300	20	50	4	15	2	2
08-11-ΓΡ60	300	20	60	4	15	2	2
08-11-ΓΛ60	300	20	60	4	15	2	2

η τιμή του σετ δεν περιλαμβάνει τα ράδια / radius have extra price

ρουλεμάν και άξονας περιλαμβάνονται / bearing and reduction bushes are included

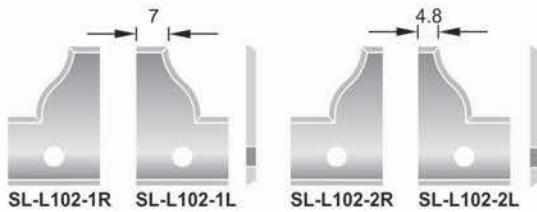

Part No	ΠΕΡΙΓΡΑΦΗ / description	TEM / pcs	
SL-L102-1R	20x30x2.0 - T15	4	
SL-L102-1L	20x30x2.0 - T15	4	
SL-L102-2R	20x30x2.0 - T15	4	
SL-L102-2L	20x30x2.0 - T15	4	
SL-L7.6	7.6x12x1.5	4	
SL-L9.6	9.6x12x1.5	4	
SL-L11.6	11.6x12x1.5	4	
SL-L13.6	13.6x12x1.5	4	
SL-L20	20x12x1.5	4	
94-01-009 (SL-L102)	ΒΙΔΑ ΚΩΝΙΚΗ M6 L16	4	
94-01-003 (SL-L7.6,SL-L9.6)	ΒΙΔΑ ΚΩΝΙΚΗ M4 L14	4	
94-01-004 (SL-L11.6)	ΒΙΔΑ ΚΩΝΙΚΗ M5 L10	4	
94-01-007 (SL-L13.6,SL-L20)	ΒΙΔΑ ΚΩΝΙΚΗ M6 L12	4	
V: προχάραξη / spur	SL-L142	ΠΡΟΧΑΡΑΞΗ 14x14x2.0	2/4
screw for spur	94-09-001	ΒΙΔΑ ΓΙΑ ΠΡΟΧΑΡΑΞΗ M5 L8	2/4
S: ράδιο / radius	SL-FKB-45	ΦΑΛΤΣΟ 16x22x5.0 - 45°	2
	SL-FKB-R2	ΡΑΔΙΟ 16x22x5.0 - R2	2
	SL-FKB-R3	ΡΑΔΙΟ 16x22x5.0 - R3	2
	SL-FKB-R4	ΡΑΔΙΟ 16x22x5.0 - R4	2
	SL-FKB-R5	ΡΑΔΙΟ 16x22x5.0 - R5	2
screw for radius	94-07-002	ΒΙΔΑ ΓΙΑ ΡΑΔΙΟ M5 L13	2
wedge			

Profile Cutterhead Set For Internal Doors

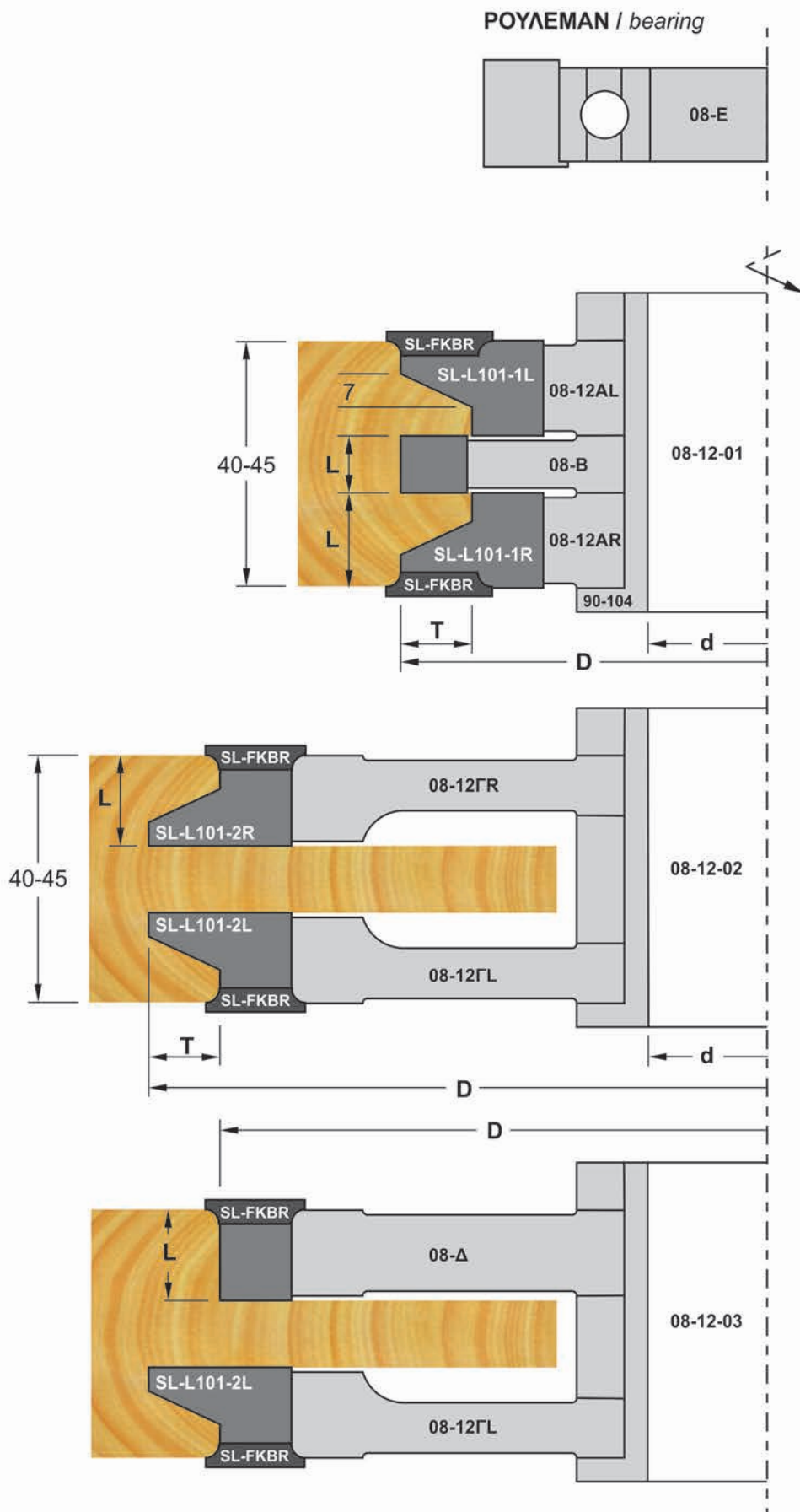



**Profile Cutterhead Set For Internal Doors**

Part No	D	L	d	Z	T	V	S
08-12-01	154	ΣΕΤ ΤΖΑΜΙΛΙΚΙΟΥ ΦΑΛΤΣΟ / cutterhead set					
08-12-02	300	ΣΕΤ ΞΕΜΟΣΣΑΡ. ΦΑΛΤΣΟ / cutterhead set					
08-12-03	300/270	ΣΕΤ ΞΕΜΟΣΣΑΡ. ΦΑΛΤΣΟ / cutterhead set					
08-08B	154	8	60	4	---	4	---
08-10B	154	10	60	4	---	4	---
08-12B	154	12	60	4	---	4	---
08-14B	154	14	60	4	---	4	---
08-E	134	25	60	ΡΟΥΛΕΜΑΝ / bearing			
90-104	60	105	35/50	ΑΞΟΝΑΣ-ΡΟΔΕΛΕΣ / spacing rings			
08-50Δ	270	20	50	4	---	4	2
08-60Δ	270	20	60	4	---	4	2
08-12-AR	154	20	60	4	15	---	2
08-12-AL	154	20	60	4	15	---	2
08-12-GR50	300	20	50	4	15	2	2
08-12-GL50	300	20	50	4	15	2	2
08-12-GR60	300	20	60	4	15	2	2
08-12-GL60	300	20	60	4	15	2	2

η τιμή του σετ δεν περιλαμβάνει τα ράδια / radius have extra price

ρουλεμάν και άξονας περιλαμβάνονται / bearing and reduction bushes are included

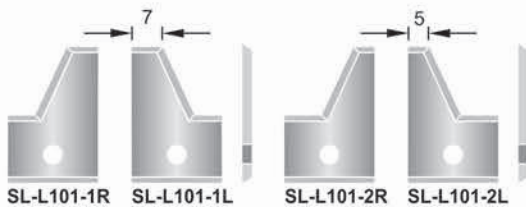

Part No	ΠΕΡΙΓΡΑΦΗ / description	TEM / pcs
SL-L101-1R	20x30x2.0 - T15	4
SL-L101-1L	20x30x2.0 - T15	4
SL-L101-2R	20x30x2.0 - T15	4
SL-L101-2L	20x30x2.0 - T15	4
	SL-L7.6 7.6x12x1.5	4
	SL-L9.6 9.6x12x1.5	4
	SL-L11.6 11.6x12x1.5	4
	SL-L13.6 13.6x12x1.5	4
	SL-L20 20x12x1.5	4
	screw	
	94-01-009 (SL-L101) ΒΙΔΑ ΚΩΝΙΚΗ M6 L16	4
	94-01-003 (SL-L7.6,SL-L9.6) ΒΙΔΑ ΚΩΝΙΚΗ M4 L14	4
	94-01-004 (SL-L11.6) ΒΙΔΑ ΚΩΝΙΚΗ M5 L10	4
	94-01-007 (SL-L13.6,SL-L20) ΒΙΔΑ ΚΩΝΙΚΗ M6 L12	4
	V: προχάραξη / spur	
	SL-L142 ΠΡΟΧΑΡΑΞΗ 14x14x2.0	2/4
	screw for spur	
	94-09-001 ΒΙΔΑ ΓΙΑ ΠΡΟΧΑΡΑΞΗ M5 L8	2/4
	S: ράδιο / radius	
	SL-FKB-45 ΦΑΛΤΣΟ 16x22x5.0 - 45°	2
	SL-FKB-R2 ΡΑΔΙΟ 16x22x5.0 - R2	2
	SL-FKB-R3 ΡΑΔΙΟ 16x22x5.0 - R3	2
	SL-FKB-R4 ΡΑΔΙΟ 16x22x5.0 - R4	2
	SL-FKB-R5 ΡΑΔΙΟ 16x22x5.0 - R5	2
	screw for radius	
	94-07-002 ΒΙΔΑ ΓΙΑ ΡΑΔΙΟ M5 L13	2
	wedge	

Profile Cutterhead Set For Internal Doors

ΡΟΥΛΕΜΑΝ / bearing

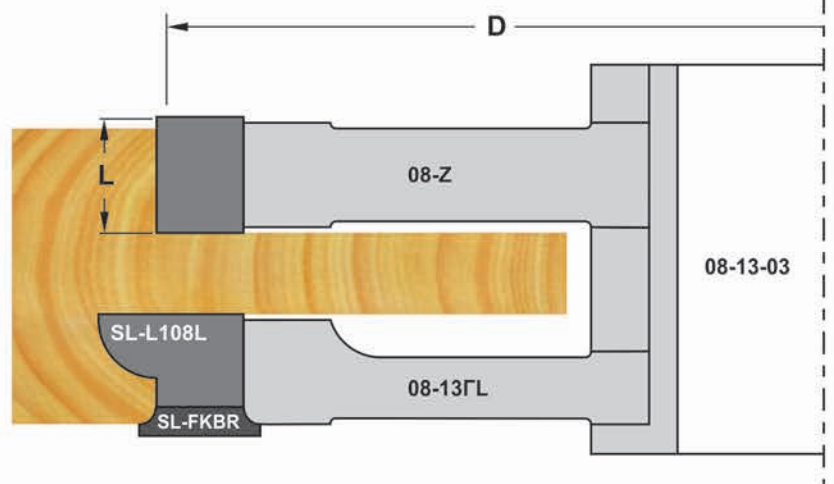
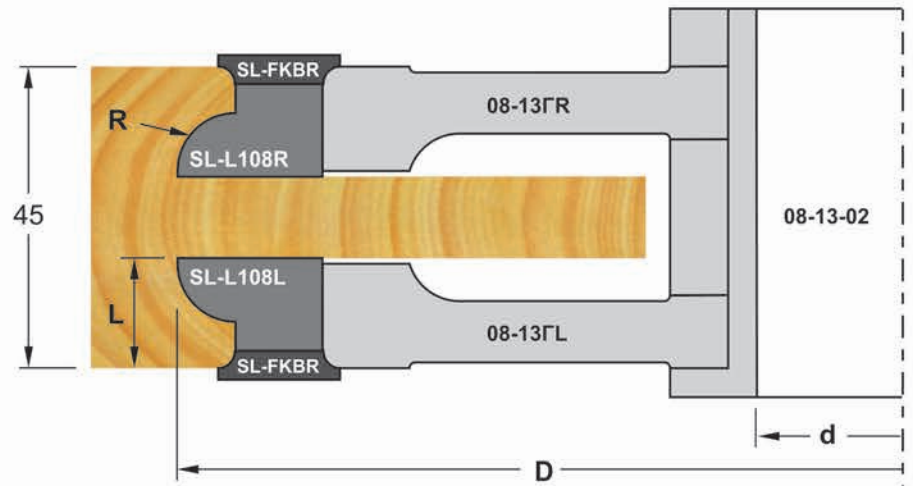
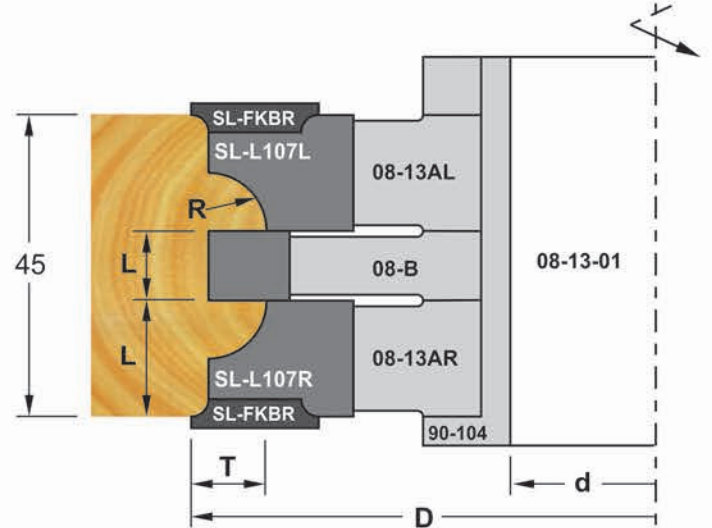
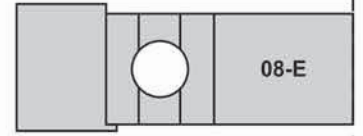















**Profile Cutterhead Set For Internal Doors**

Part No	D	L	d	Z	T	V	S
08-13-01	154	ΣΕΤ ΤΖΑΜΙΛΙΚΙΟΥ ΡΑΔΙΟΥ / cutterhead set					
08-13-02	300	ΣΕΤ ΞΕΜΟΣΣΑΡ. ΡΑΔΙΟΥ / cutterhead set					
08-13-03	300/270	ΣΕΤ ΞΕΜΟΣΣΑΡ. ΡΑΔΙΟΥ / cutterhead set					
08-10B	154	10	60	4	---	4	---
08-12B	154	12	60	4	---	4	---
08-14B	154	14	60	4	---	4	---
08-E	134	25	60	ΡΟΥΛΕΜΑΝ / bearing			
90-104	60	105	60	ΑΞΟΝΑΣ-ΡΟΔΕΛΕΣ / spacing rings			
08-60Z	270	20	60	4	---	4	---
08-13-AR	154	20	60	4	10	2	2
08-13-AL	154	20	60	4	10	2	2
08-13-FR	300	20	60	4	10	2	2
08-13-ΓL	300	20	60	4	10	2	2

η τιμή του σετ δεν περιλαμβάνει τα ράδια / radius have extra price

ρουλεμάν και άξονας περιλαμβάνονται / bearing and reduction bushes are included

Part No	ΠΕΡΙΓΡΑΦΗ / description	TEM / pcs
 SL-L107L	20x25x2.0 - R10	4
 SL-L107R	20x25x2.0 - R10	4
 SL-L108R	20x25x2.0 - R10	4
 SL-L108L	20x25x2.0 - R10	4
 SL-L9.6	9.6x12x1.5	4
 SL-L11.6	11.6x12x1.5	4
 SL-L13.6	13.6x12x1.5	4
 SL-L20	20x12x1.5	4
 screw	94-01-009 (SL-L107,SL-L108) ΒΙΔΑ ΚΩΝΙΚΗ M6 L16 94-01-003 (SL-L9.6) ΒΙΔΑ ΚΩΝΙΚΗ M4 L14 94-01-004 (SL-L11.6) ΒΙΔΑ ΚΩΝΙΚΗ M5 L10 94-01-007 (SL-L13.6,SL-L20) ΒΙΔΑ ΚΩΝΙΚΗ M6 L12	4 4 4 4
 V: προχάραξη / spur	SL-L142 ΠΡΟΧΑΡΑΞΗ 14x14x2.0	2/4
 screw for spur	94-09-001 ΒΙΔΑ ΓΙΑ ΠΡΟΧΑΡΑΞΗ M5 L8	2/4
 S: ράδιο / radius	SL-FKB-45 ΦΑΛΤΣΟ 16x22x5.0 - 45° SL-FKB-R2 ΡΑΔΙΟ 16x22x5.0 - R2 SL-FKB-R3 ΡΑΔΙΟ 16x22x5.0 - R3 SL-FKB-R4 ΡΑΔΙΟ 16x22x5.0 - R4 SL-FKB-R5 ΡΑΔΙΟ 16x22x5.0 - R5	2 2 2 2 2
 screw for radius	94-07-002 ΒΙΔΑ ΓΙΑ ΡΑΔΙΟ M5 L13	2
 wedge		



Profile Cutterhead Set For Internal Doors

ΡΟΥΛΕΜΑΝ / bearing

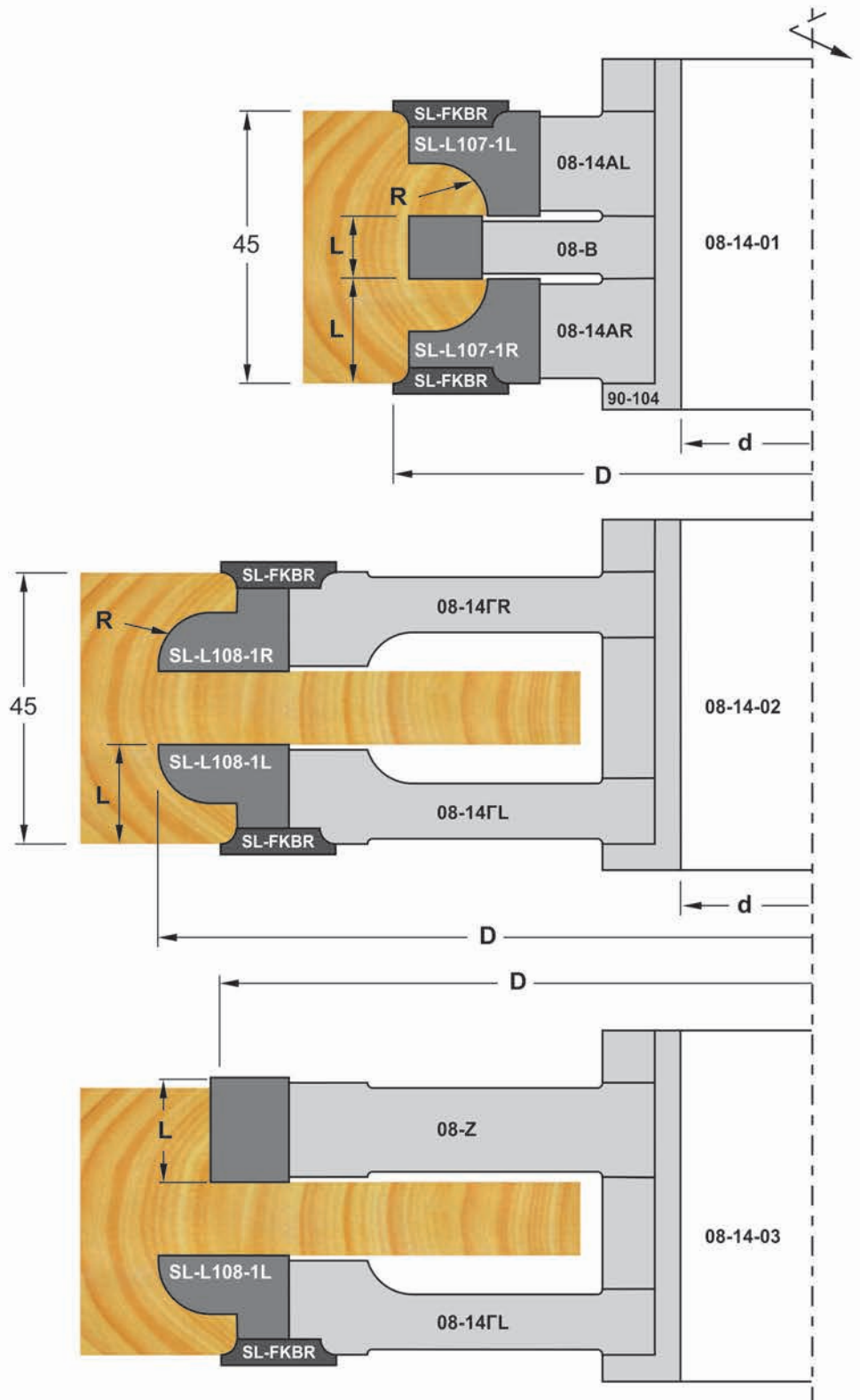
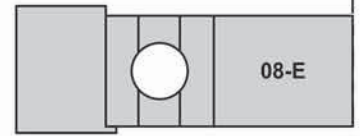













**Profile Cutterhead Set For Internal Doors**

Part No	D	L	d	Z	T	V	S
08-14-01	154	ΣΕΤ ΤΖΑΜΙΛΙΚΙΟΥ ΡΑΔΙΟΥ / cutterhead set					
08-14-02	300	ΣΕΤ ΞΕΜΟΣΣΑΡ. ΡΑΔΙΟΥ / cutterhead set					
08-14-03	300/270	ΣΕΤ ΞΕΜΟΣΣΑΡ. ΡΑΔΙΟΥ / cutterhead set					
08-10B	154	10	60	4	---	4	---
08-12B	154	12	60	4	---	4	---
08-14B	154	14	60	4	---	4	---
08-E	134	25	60	ΡΟΥΛΕΜΑΝ / bearing			
90-104	60	105	60	ΑΞΟΝΑΣ-ΡΟΔΕΛΕΣ / spacing rings			
08-60Z	270	20	60	4	---	4	---
08-14-AR	154	20	60	4	10	2	2
08-14-AL	154	20	60	4	10	2	2
08-14-FR	300	20	60	4	10	2	2
08-14-FL	300	20	60	4	10	2	2

η τιμή του σετ δεν περιλαμβάνει τα ράδια / radius have extra price

ρουλεμάν και άξονας περιλαμβάνονται / bearing and reduction bushes are included

Part No	ΠΕΡΙΓΡΑΦΗ / description	TEM / pcs
 SL-L107-1L SL-L107-1R	20x30x2.0 - R10 20x30x2.0 - R10	4 4
 SL-L108-1R SL-L108-1L	20x30x2.0 - R10 20x30x2.0 - R10	4 4
 SL-L9.6 SL-L11.6	9.6x12x1.5 11.6x12x1.5	4 4
 SL-L13.6 SL-L20	13.6x12x1.5 20x12x1.5	4 4
 screw	94-01-009 (SL-L107,SL-L108) ΒΙΔΑ ΚΩΝΙΚΗ M6 L16 94-01-003 (SL-L9.6) ΒΙΔΑ ΚΩΝΙΚΗ M4 L14 94-01-004 (SL-L11.6) ΒΙΔΑ ΚΩΝΙΚΗ M5 L10 94-01-007 (SL-L13.6,SL-L20) ΒΙΔΑ ΚΩΝΙΚΗ M6 L12	4 4 4 4
 V: προχάραξη / spur	SL-L142 ΠΡΟΧΑΡΑΞΗ 14x14x2.0	2/4
 screw for spur	94-09-001 ΒΙΔΑ ΓΙΑ ΠΡΟΧΑΡΑΞΗ M5 L8	2/4
 S: ράδιο / radius	SL-FKB-45 ΦΑΛΤΣΟ 16x22x5.0 - 45° SL-FKB-R2 ΡΑΔΙΟ 16x22x5.0 - R2 SL-FKB-R3 ΡΑΔΙΟ 16x22x5.0 - R3 SL-FKB-R4 ΡΑΔΙΟ 16x22x5.0 - R4 SL-FKB-R5 ΡΑΔΙΟ 16x22x5.0 - R5	2 2 2 2 2
 screw for radius	94-07-002 ΒΙΔΑ ΓΙΑ ΡΑΔΙΟ M5 L13	2
 wedge		

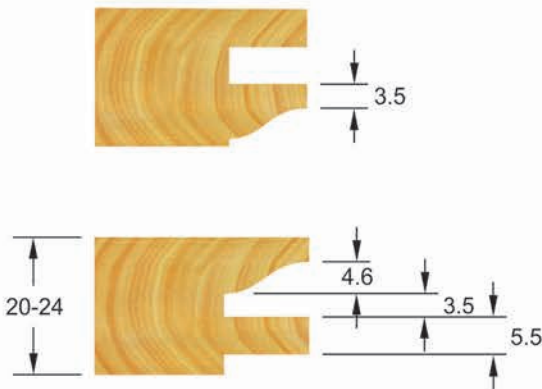
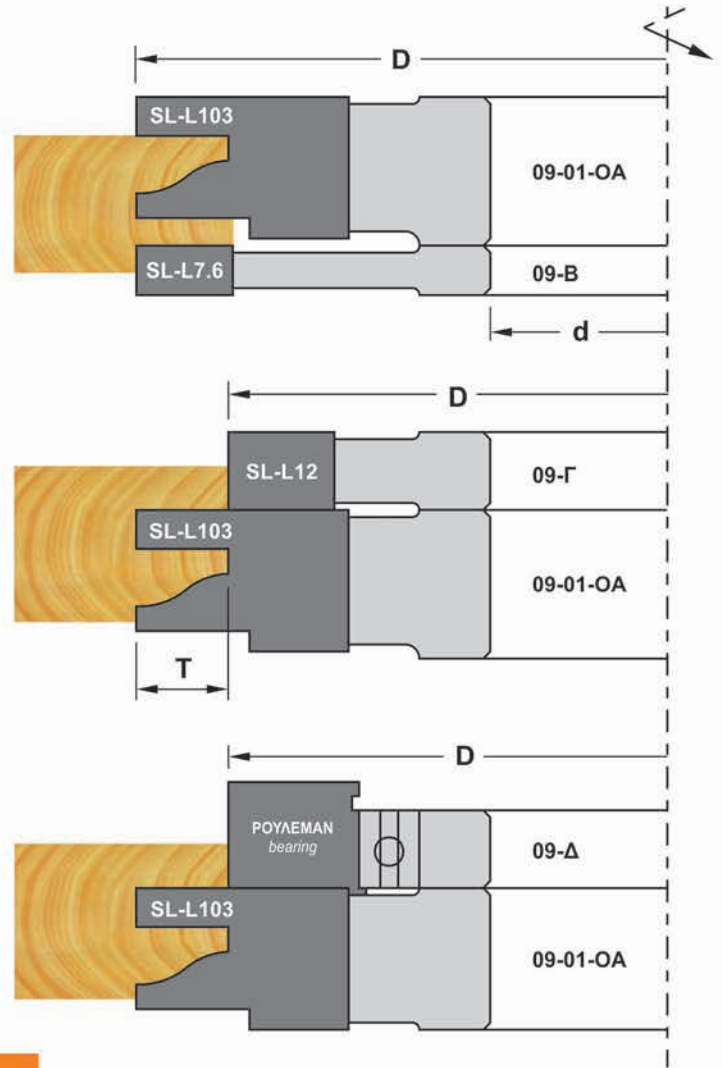

Part No	D	d	Z	T	V
09-01	150	ΣΕΤ ΚΟΥΖΙΝΑΣ / cutterhead set			
09-01-OA	150	35/50	4	13	---
09-OB	150	35/50	4	---	4
09-ΟΓ	124	35/50	4	---	---
09-ΟΔ	124	35/50	ΡΟΥΛΕΜΑΝ / bearing		



Part No	ΠΕΡΙΓΡΑΦΗ / description	TEM / pcs
SL-L103	20x30x2.0 - T13	4
SL-L7.6	7.6x12x1.5	4
SL-L12	12x12x1.5	4
94-01-009 (SL-L103)	ΒΙΔΑ ΚΩΝΙΚΗ M6 L16	4
94-01-002 (SL-L7.6)	ΒΙΔΑ ΚΩΝΙΚΗ M4 L10	4
94-01-004 (SL-L12)	ΒΙΔΑ ΚΩΝΙΚΗ M5 L10	4
SL-L142	ΠΡΟΧΑΡΑΞΗ 14x14x2.0	4
94-09-001	ΒΙΔΑ ΓΙΑ ΠΡΟΧΑΡΑΞΗ M5 L8	4

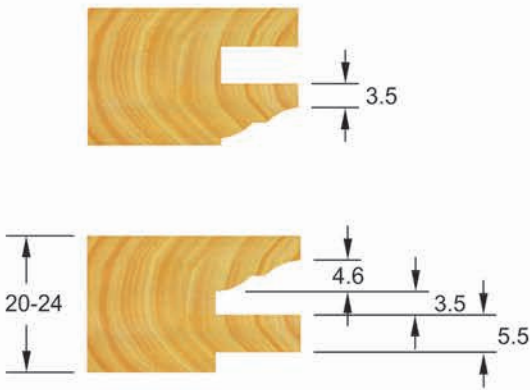
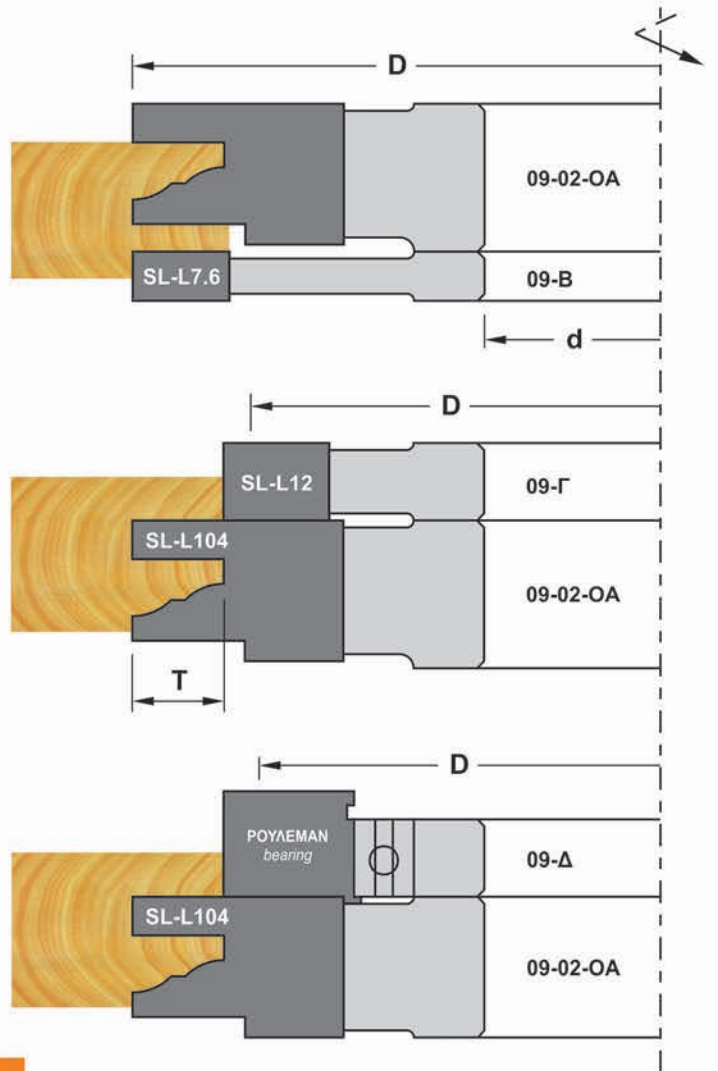

Part No	D	d	Z	T	V
09-02	150	ΣΕΤ ΚΟΥΖΙΝΑΣ / cutterhead set			
09-02-OA	150	35/50	4	13	---
09-OB	150	35/50	4	---	4
09-ΟΓ	124	35/50	4	---	---
09-ΟΔ	124	35/50	ΡΟΥΛΕΜΑΝ / bearing		



Part No	ΠΕΡΙΓΡΑΦΗ / description	TEM / pcs
SL-L104	20x30x2.0 - T13	4
SL-L7.6	7.6x12x1.5	4
SL-L12	12x12x1.5	4
94-01-009 (SL-L104)	ΒΙΔΑ ΚΩΝΙΚΗ M6 L16	4
94-01-002 (SL-L7.6)	ΒΙΔΑ ΚΩΝΙΚΗ M4 L10	4
94-01-004 (SL-L12)	ΒΙΔΑ ΚΩΝΙΚΗ M5 L10	4
SL-L142	ΠΡΟΧΑΡΑΞΗ 14x14x2.0	4
94-09-001	ΒΙΔΑ ΓΙΑ ΠΡΟΧΑΡΑΞΗ M5 L8	4
93-032	ΣΦΥΚΤΗΡΑΣ ΓΙΑ SL-L104	4
93-019	ΣΦΥΚΤΗΡΑΣ ΓΙΑ SL-L7.6	4
93-013	ΣΦΥΚΤΗΡΑΣ ΓΙΑ SL-L12	4



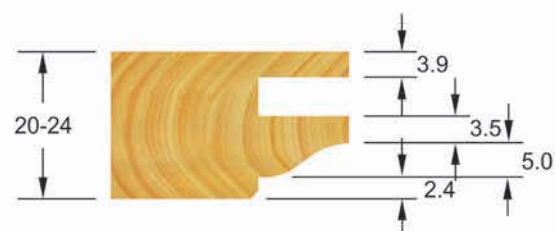
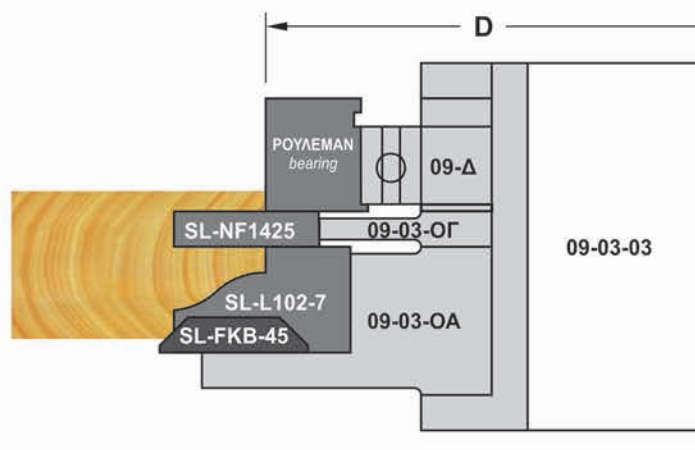
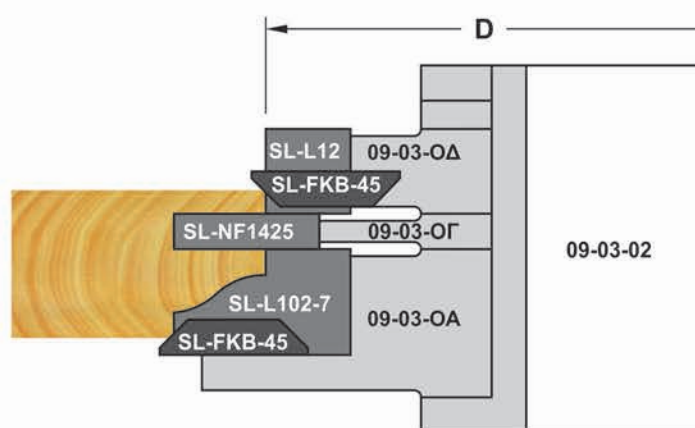
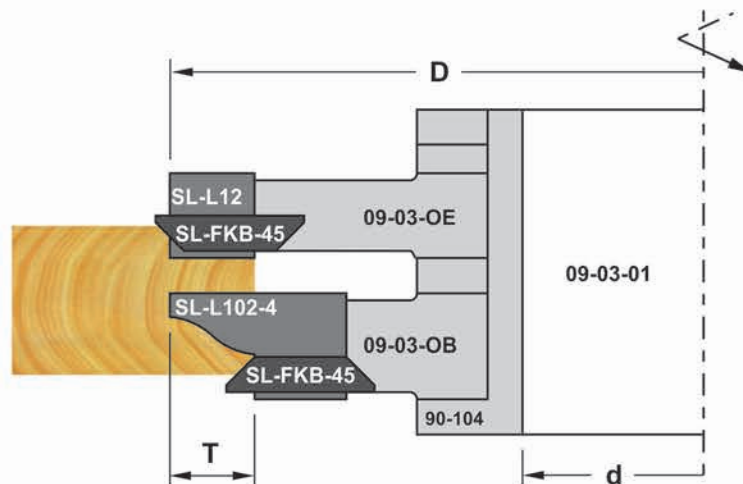

#### Υποσημείωση:

Το εργαλείο παραδίνεται για ξύλο πάχους 20 χιλ. Πίσω από το πλακίδιο **SL-FKB-45** των εργαλείων **SS 09-03-0E**, **SS 09-03-0A**, **SS 09-03-0A**, υπάρχει ροδέλα πάχους 1 χιλ. Για να βγάλουμε ξύλο πάχους 22 χιλ. με το ίδιο σπάσιμο πρέπει να βγάλουμε τις ροδέλες από τα πλακίδια των εργαλείων που αναφέρθηκαν και να βάλουμε μια ροδέλα πίσω από το πλακίδιο **SL-FKB-45** του εργαλείου **SS 09-03-0B** πάχους 1 χιλ.



Part No	D	d	Z	T	V	V1	S
09-03-01	150		ΣΕΤ ΚΟΥΖΙΝΑΣ / cutterhead set				
09-03-02	150		ΣΕΤ ΚΟΥΖΙΝΑΣ / cutterhead set				
09-03-03	150		ΣΕΤ ΚΟΥΖΙΝΑΣ / cutterhead set				
09-03-0A	150	35/50	4	12	---	---	2
09-03-0B	150	35/50	4	12	2	---	2
09-03-0Γ	150	35/50	4	---	---	4	---
09-03-0Δ	124	35/50	4	---	---	---	2
09-03-0E	150	35/50	4	---	2	---	2
09-0Δ	124	35/50	ΡΟΥΛΕΜΑΝ / bearing				
90-104	60	50	ΑΞΟΝΑΣ-ΡΟΔΕΛΕΣ / spacing rings				

η τιμή του σετ δεν περιλαμβάνει τα ράδια / radius have extra price

ρουλεμάν και άξονας περιλαμβάνονται / bearing and reduction bushes are included



Part No	ΠΕΡΙΓΡΑΦΗ / description	ΤΕΜ / pcs
SL-L102-7R	15x25x2.0 - T12	4
SL-L102-7L	15x25x2.0 - T12	4
SL-L102-4R	15x25x2.0 - T12	4
SL-L102-4L	15x25x2.0 - T12	4
94-01-007	ΒΙΔΑ ΚΩΝΙΚΗ M6 L12	4
SL-L12	12x12x1.5	4
94-01-004	ΒΙΔΑ ΚΩΝΙΚΗ M5 L10	4
SL-L141	ΠΡΟΧΑΡΑΞΗ 14x14x1.2	4
94-16-001	ΕΙΔΙΚΗ ΒΙΔΑ	4
SL-NF1425	14x14x2.5	4
94-16-001	ΕΙΔΙΚΗ ΒΙΔΑ	4
SL-L142	ΠΡΟΧΑΡΑΞΗ 14x14x2.0	2
94-09-001	ΒΙΔΑ ΓΙΑ ΠΡΟΧΑΡΑΞΗ M5 L8	2
SL-FKB-45	ΦΑΛΤΣΟ 16x22x5.0 - 45°	2
SL-FKB-R2	ΡΑΔΙΟ 16x22x5.0 - R2	2
SL-FKB-R3	ΡΑΔΙΟ 16x22x5.0 - R3	2
SL-FKB-R4	ΡΑΔΙΟ 16x22x5.0 - R4	2
SL-FKB-R5	ΡΑΔΙΟ 16x22x5.0 - R5	2
94-07-002	ΒΙΔΑ ΓΙΑ ΡΑΔΙΟ M5 L13	2
	wedge	

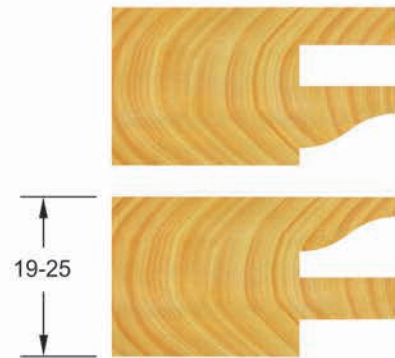
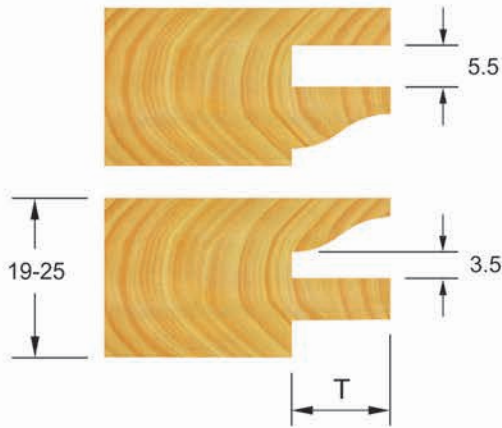
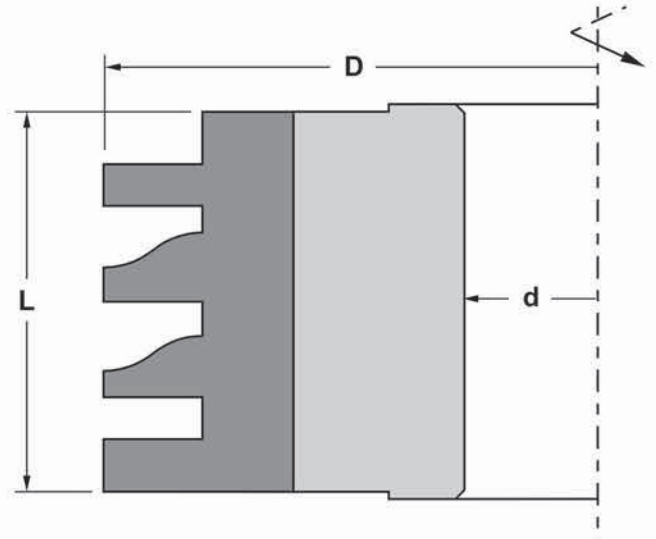

Part No	D	L	d	Z	T
09-05-5035	130	50	35	4	13



screw



wedge

Part No	ΠΕΡΙΓΡΑΦΗ / description	TEM / pcs
SL-L105	50x30x2.0 - T13	4
94-01-012	ΒΙΔΑ ΚΩΝΙΚΗ M8 L12	8

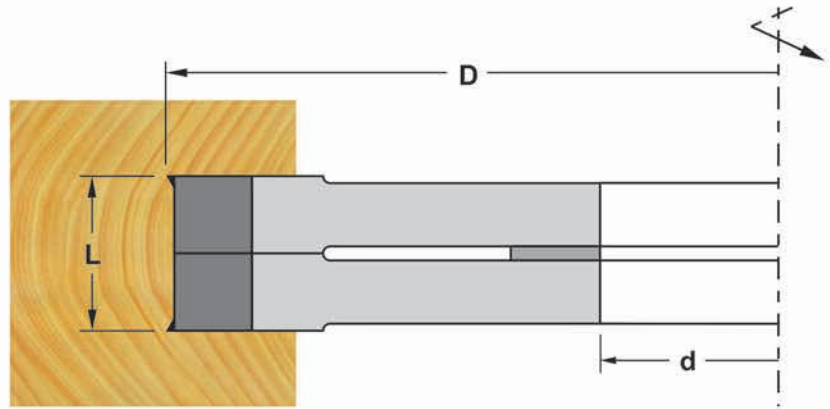

Part No	D	L	d	Z	V
09-06-16008	160	8-15	50	4	4
09-06-16012	160	12.5-24	50	4	4
09-06-16016	160	16-30	50	4	4
09-06-180-4-7.5	180	4-7.5	50	8	4
09-06-21012	210	12.5-24	50	4	4



screw



screw



V: προχάραξη / spur



screw for spur



wedge

Part No	ΠΕΡΙΓΡΑΦΗ / description	TEM / pcs
SL-L12 (09-06-16012) (09-06-21012)	12x12x1.5	4
SL-L7.6 (09-06-16008)	7.6x12x1.5	4
SL-NF1820 (09-06-180-4-7.5)	18x18x1.95	8
94-01-007(SL-L12) 94-01-002(SL-L7.6)	ΒΙΔΑ ΚΩΝΙΚΗ M6 L12 ΒΙΔΑ ΚΩΝΙΚΗ M4 L10	4 4
SL-L15.7 (09-06-16016)	15.7x12x1.5	4
94-01-007	ΒΙΔΑ ΚΩΝΙΚΗ M6x12	4
SL-L142 SL-L141(09-06-180-4-7.5)	ΠΡΟΧΑΡΑΞΗ 14x14x2.0 ΠΡΟΧΑΡΑΞΗ 14x14x1.2	4 4
94-09-001	ΒΙΔΑ ΓΙΑ ΠΡΟΧΑΡΑΞΗ M5 L8	4

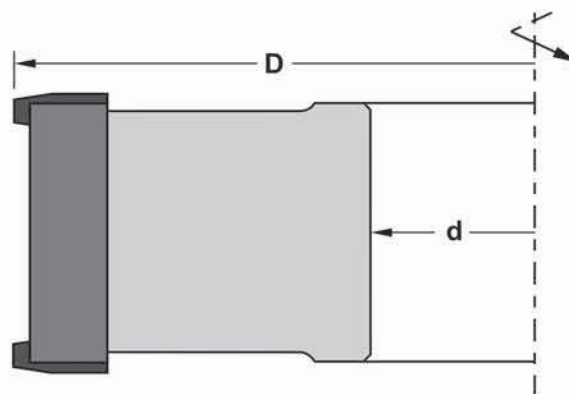

η τιμή της φρέζας δεν περιλαμβάνει τα αστεράκια /  
chamfer knives have extra price

Part No	D	L	d	Z	I
11-03-14030	140/143	30	40	4	4
11-03-14040	140/143	40	40	4	4
11-03-14050	140/143	50	40	4	4
11-03-15130	150/153	30	50	6	4
11-03-15140	150/153	40	50	6	4
11-03-15150	150/153	50	50	6	4
11-03-15160	150/153	60	50	6	4
11-03-16030	160/163	30	40	6	6
11-03-16041	160/163	40	40	6	6
11-03-16050	160/163	50	40	6	6
11-03-18051	180/183	50	50	6	---

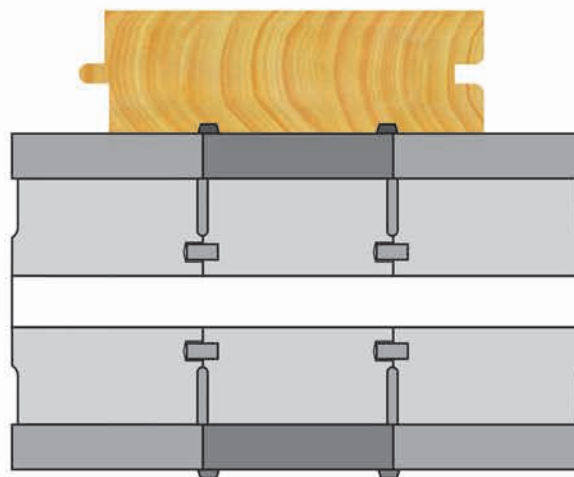

screw



I: αστεράκι / chamfer knife



screw for chamfer knife



wedge





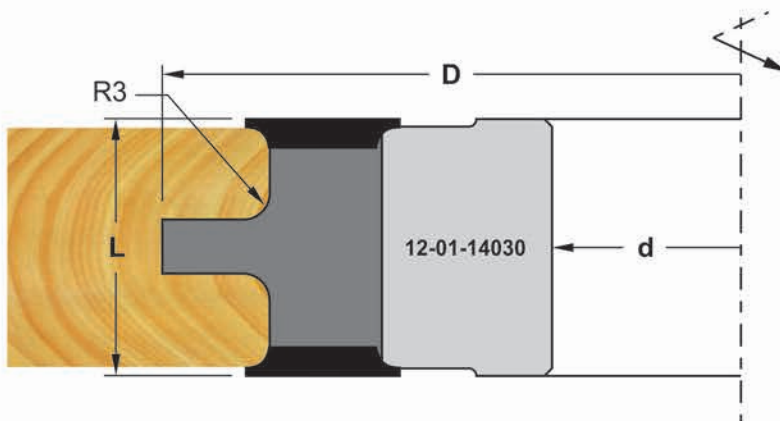
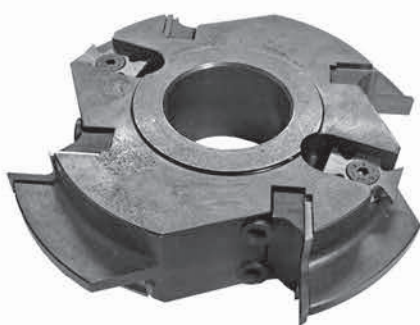
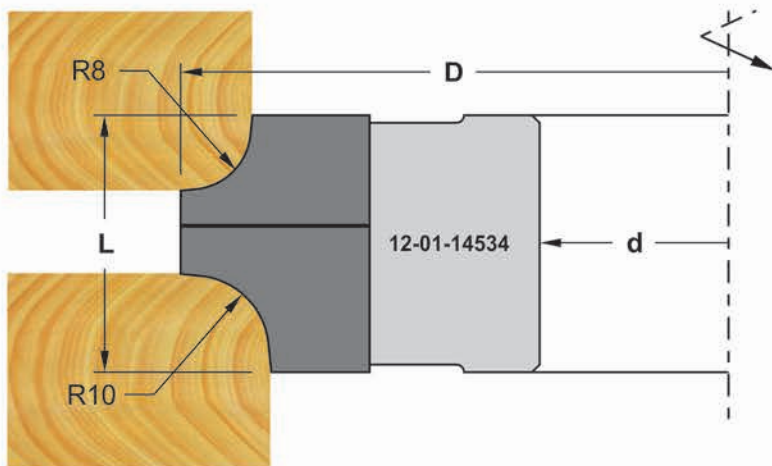

Part No	ΠΕΡΙΓΡΑΦΗ / description	ΤΕΜ / pcs
SL-L30	30x12x1.5	4/6
SL-L40	40x12x1.5	4/6
SL-L50	50x12x1.5	4/6
SL-L60	60x12x1.5	6
94-01-007	ΒΙΔΑ ΚΩΝΙΚΗ M6 L12	8/12
SL-MUSTER	ΑΣΤΕΡΑΚΙ 23x23x5.5	4/6
94-07-002	ΒΙΔΑ ΓΙΑ ΑΣΤΕΡΑΚΙ M5 L13	4/6
93-002	ΣΦΥΚΤΗΡΑΣ ΓΙΑ SL-L30	4/6
93-010	ΣΦΥΚΤΗΡΑΣ ΓΙΑ SL-L40	4/6
93-004	ΣΦΥΚΤΗΡΑΣ ΓΙΑ SL-L50	4/6
93-011	ΣΦΥΚΤΗΡΑΣ ΓΙΑ SL-L60	6





η τιμή της φρέζας δεν περιλαμβάνει τα ραδια / radius have extra price

Part No	D	L	d	Z	R	S
12-01-14534	145	34	50	3+3	8/10	
12-01-14030	140	30	40	4	3	4

Part No	ΠΕΡΙΓΡΑΦΗ / description	TEM / pcs
 SL-L109-8	15x25x2.0 - R8	3
 SL-L109-10	20x25x2.0 - R10	3
 63-0586	30x30x2.0 - R3	4
 screw	94-01-007(12-01-14534) ΒΙΔΑ ΚΩΝΙΚΗ M6 L12 94-01-007(12-01-14030) ΒΙΔΑ ΚΩΝΙΚΗ M6 L12	6 8
 S: ράδιο / radius	SL-FKB-45 ΦΑΛΤΣΟ 16x22x5.0 - 45° SL-FKB-R2 ΡΑΔΙΟ 16x22x5.0 - R2 SL-FKB-R3 ΡΑΔΙΟ 16x22x5.0 - R3 SL-FKB-R4 ΡΑΔΙΟ 16x22x5.0 - R4 SL-FKB-R5 ΡΑΔΙΟ 16x22x5.0 - R5	4 4 4 4 4
 screw for radius	94-07-002 ΒΙΔΑ ΓΙΑ ΡΑΔΙΟ M5 L13	4
 wedge		

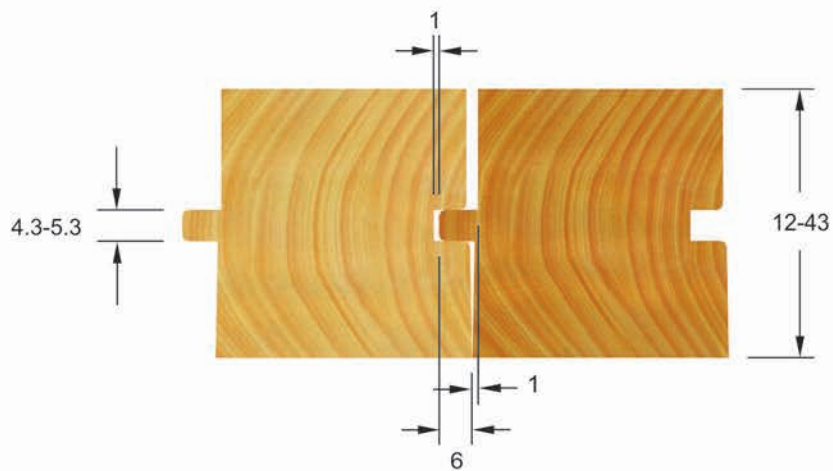
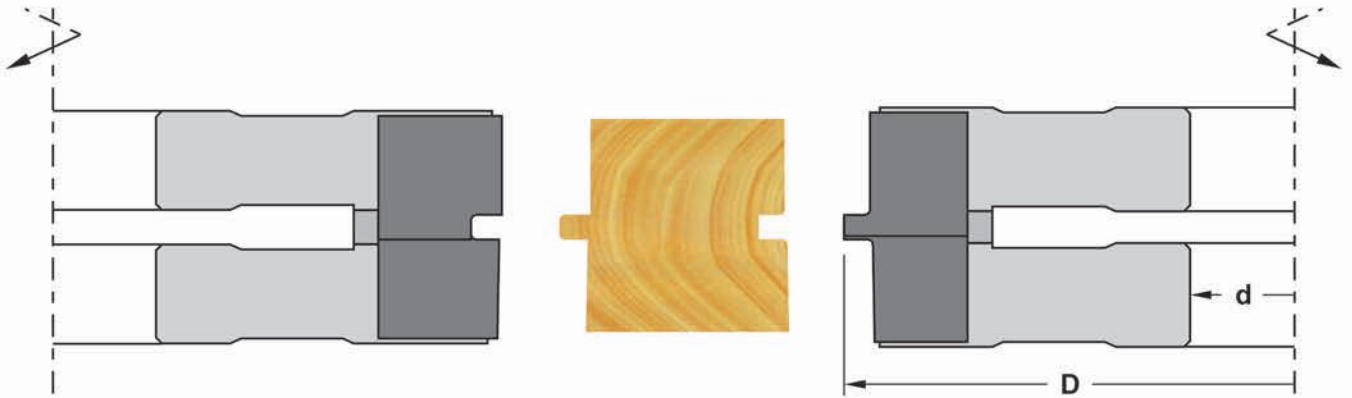

Part No	D	d	Z
11-04	160	40	6
11-041	160	40	6

Part No	D	d	Z
11-05-SET	160	60	6



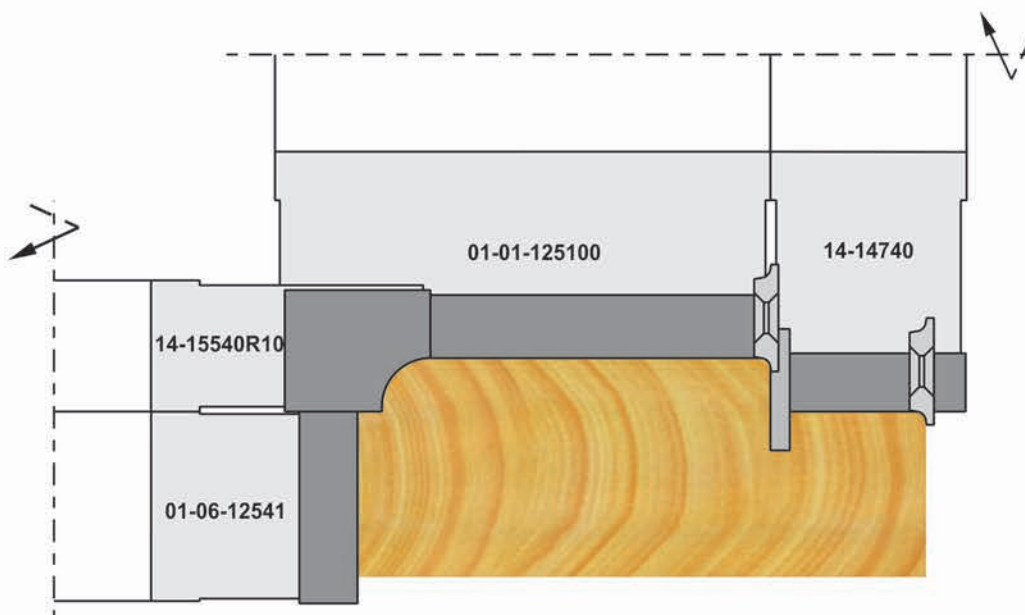





	Part No	ΠΕΡΙΓΡΑΦΗ / description	TEM / pcs
	SH-PAR1	25x24x3.0	6
	SH-PAR2	25x23.5x3.0	6
	SH-PAR3	25x23x3.0	6
	SH-PAR4	25x22.5x3.0	6
 screw	94-02-004	ΒΙΔΑ ΠΙΕΣΕΩΣ M10 L20	6
 wedge	93-047 93-048 93-049 93-050	ΣΦΥΚΤΗΡΑΣ ΓΙΑ SH-PAR1 ΣΦΥΚΤΗΡΑΣ ΓΙΑ SH-PAR2 ΣΦΥΚΤΗΡΕΣ ΓΙΑ SH-PAR3 ΣΦΥΚΤΗΡΕΣ ΓΙΑ SH-PAR4	6 6 6 6



τα εργαλεία δένονται σε άξονες

Part No	D	L	d	Z	I	S
01-06-12541	125	40	40	4	---	---
14-15540R10	155	25	40	4	---	---
01-01-125100	125	100	40	4	---	2
14-14740	147	40	40	4	2	2

η τιμή της φρέζας δεν περιλαμβάνει τα λάστιχα και τα ράδια /  
grooving knives and radius have extra price

		Part No	ΠΕΡΙΓΡΑΦΗ / description	ΤΕΜ / pcs
		SL-L100 SL-L40	100x13x2.2 40x12x1.5	4 4
	screw	94-02-003	ΒΙΔΑ ΠΙΕΣΕΩΣ M8 L16	12=L100 8=L40
		63-0430	25x30x2.0 - R10	4
	screw	94-01-009	ΒΙΔΑ ΚΩΝΙΚΗ M6 L16	4
	S: ράδιο / radius	SL-FKB-45 SL-FKB-R2 SL-FKB-R3 SL-FKB-R4 SL-FKB-R5	ΦΑΛΤΣΟ 13x22x5.0 - 45° ΡΑΔΙΟ 13x22x5.0 - R2 ΡΑΔΙΟ 13x22x5.0 - R3 ΡΑΔΙΟ 13x22x5.0 - R4 ΡΑΔΙΟ 13x22x5.0 - R5	2 2 2 2 2
	screw for radius	94-07-002	ΒΙΔΑ ΓΙΑ ΡΑΔΙΟ M5 L13	2
	I: λάστιχο / grooving knife	SL-FKB4R SL-FKB5R	ΛΑΣΤΙΧΟ 34x16x4.0 ΛΑΣΤΙΧΟ 34x16x5.0	2 2
	screw for grooving knife	94-09-001	ΒΙΔΑ ΓΙΑ ΛΑΣΤΙΧΟ M5 L8	2
	wedge	93-010 93-008	ΣΦΥΚΤΗΡΑΣ ΓΙΑ SL-L40 ΣΦΥΚΤΗΡΑΣ ΓΙΑ SL-L100 ΣΦΥΚΤΗΡΑΣ ΓΙΑ 63-0430	4 4 4



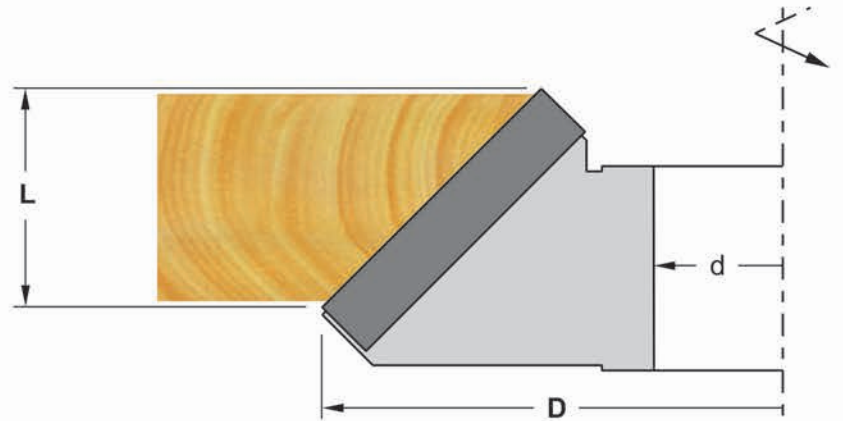

Part No	D	L	d	Z	ΞΥΛΟ
15-01-17843	178	43	50	4	40
15-01-14524	145	24.8	50	4	22

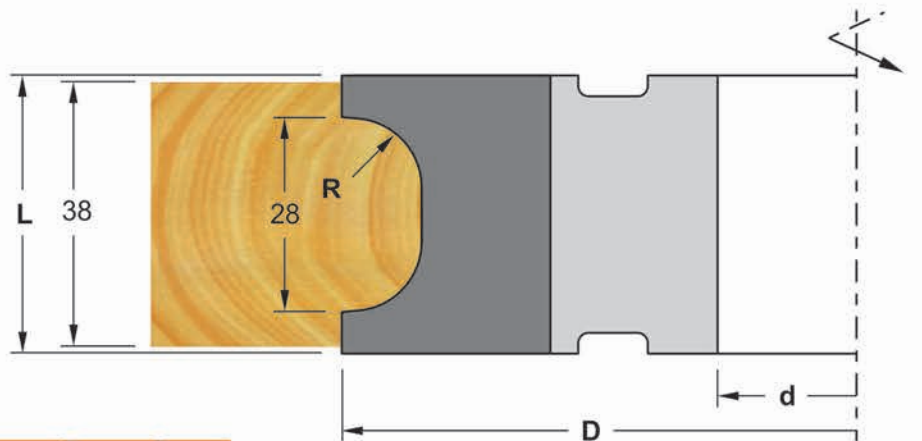

Part No	D	L	d	Z	R
16-01-14840	148	40	40/50	4	10
16-01-14841	148	40	40/50	4	8
16-01-14842	148	40	40/50	4	5



**SS 15-01-17843**



**SS16-01**



screw



wedge

Part No	ΠΕΡΙΓΡΑΦΗ / description	TEM / pcs
SL-L60	60x12x1.5	4
SL-L35	35x12x1.5	4
63-0039R5	40x30x2 - R5	4
63-0039R8	40x30x2 - R8	4
63-0039R10	40x30x2 - R10	4
94-01-007	ΒΙΔΑ ΚΩΝΙΚΗ M6 L12	8
93-011	ΣΦΥΚΤΗΡΑΣ ΓΙΑ SL-L60	4

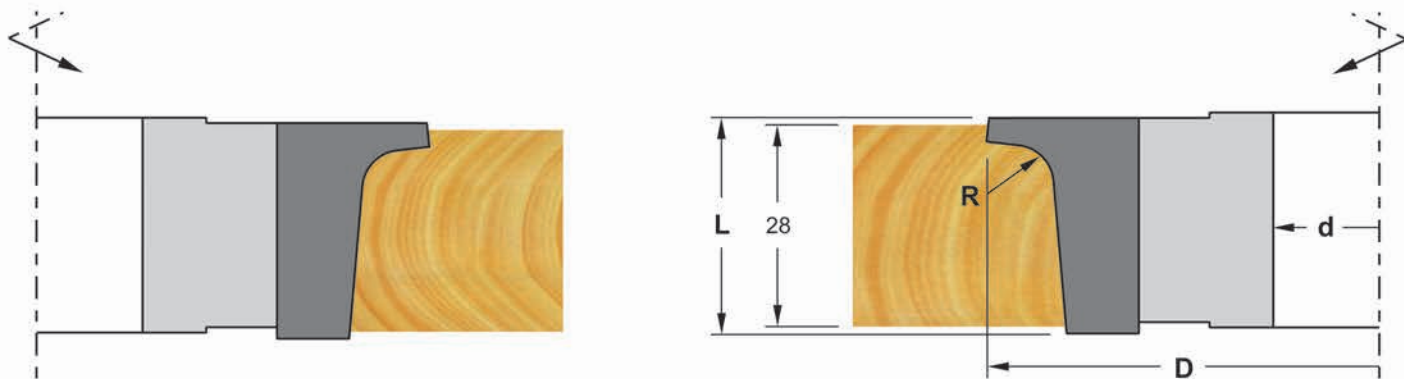

Part No	D	L	d	Z	R
17-01-11830R	118	30	30	3	5.5
17-01-11830L	118	30	30	3	5.5

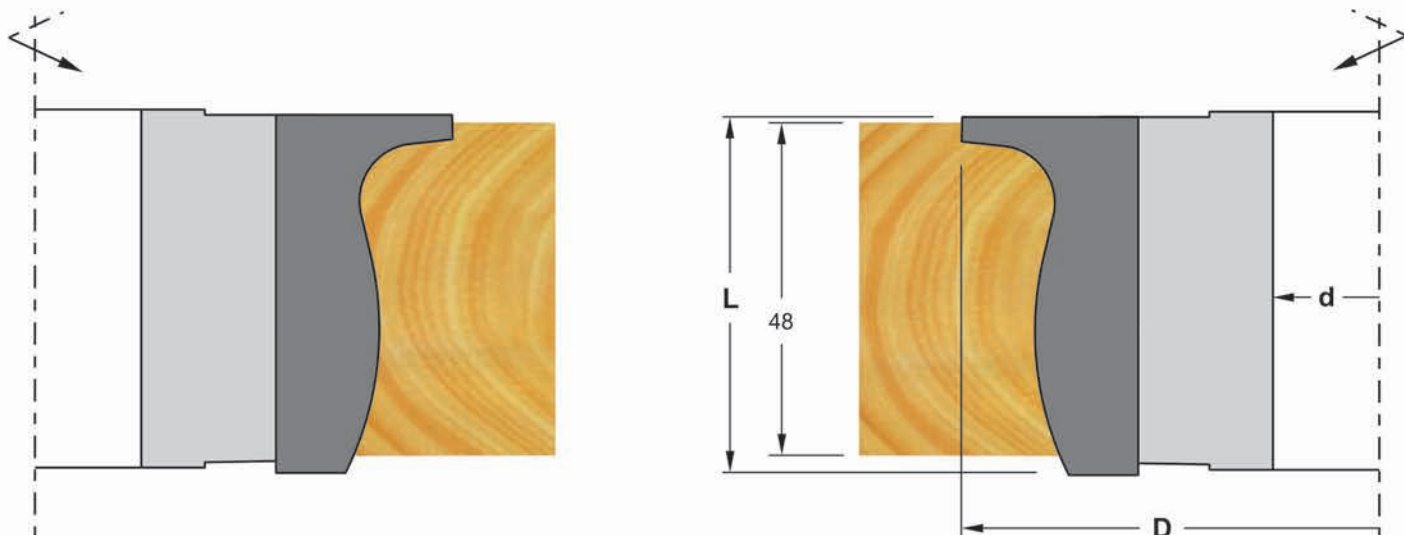

Part No	D	L	d	Z
17-02-11850R	118	50	30	3
17-02-11850L	118	50	30	3

63-0261

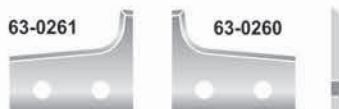

63-0260



Part No	ΠΕΡΙΓΡΑΦΗ / description	TEM / pcs
63-0260	30x21.5x2.0	3
63-0261	30x21.5x2.0	3

63-0287



63-0288



63-0287	50x25x2.0	3
63-0288	30x25x2.0	3



screw

94-01-007	ΒΙΔΑ ΚΩΝΙΚΗ M6 L12	6
-----------	--------------------	---





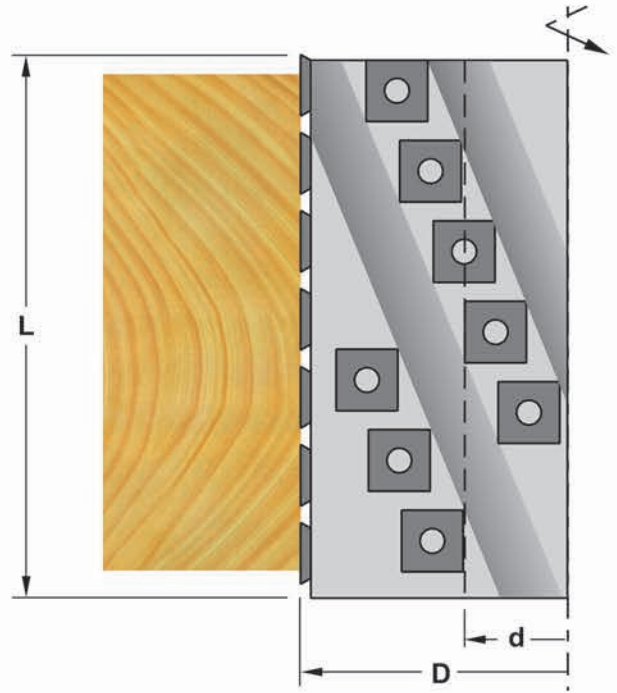

wedge

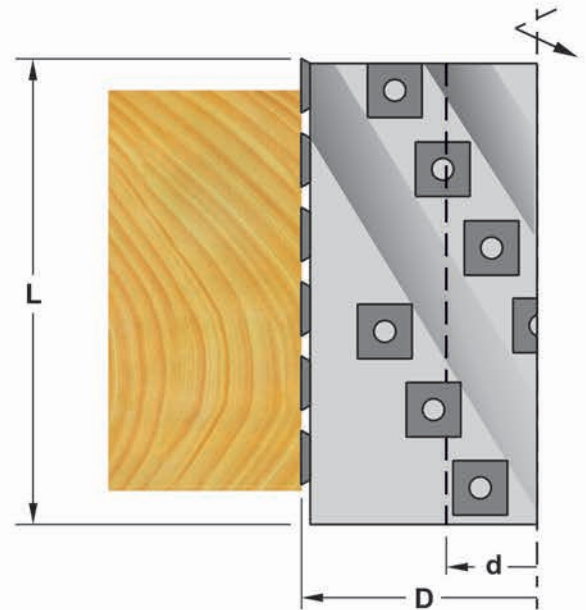

Part No	D	L	d	Z
18-01-125131	125	131	50	39



Part No	D	L	d	Z
18-02-125127	125	127	50	20
18-02-125182	125	182	40	30

	Part No	ΠΕΡΙΓΡΑΦΗ / description	TEM / pcs
 για SS 18-02 / for SS 18-02	SL-L142	14x14x2.0	20/30
 για SS 18-01 / for SS 18-01	SL-L15/13320T	15x15x2.5	39
 screw	94-08-001	ΒΙΔΑ ΦΡΕΖΑΤΗ ΜΕ ΚΟΛΑΡΟ Μ5 L16	20/39
 wedge			

## Cutterhead Set For Sliding Doors

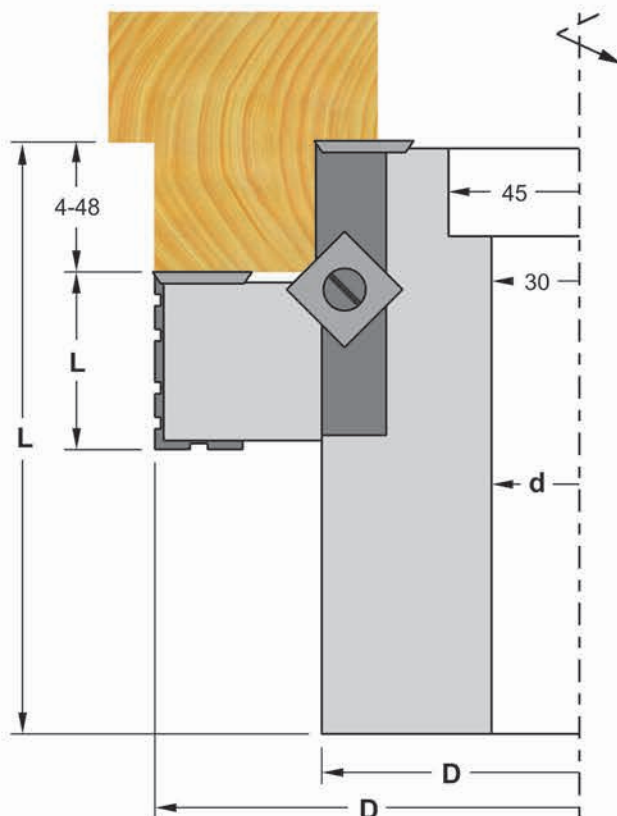

Part No	D	L	d	Z	V
19-01-90	90	90	30/45	4	4
PADE	145	30	88	6	2+2

Part No	D	L	d	Z	V
19-01-100	90	100	30/45	4	4
BACI	145	30	88	6	2+2



Part No	ΠΕΡΙΓΡΑΦΗ / description	ΤΕΜ / pcs
SL-L15CB	15x15x2.0	12
94-02-001 (SL-L15CB)	ΒΙΔΑ M6x12	12
94-02-001 (SL-L60)	ΒΙΔΑ M6x12	12
SL-L60	60x12x1.5	4
SL-L142	ΠΡΟΧΑΡΑΞΗ 14x14x2.0	4
94-09-001	ΒΙΔΑ ΓΙΑ ΠΡΟΧΑΡΑΞΗ M5 L8	4
93-005	ΣΦΥΚΤΗΡΑΣ ΓΙΑ SL-L15	12
93-011	ΣΦΥΚΤΗΡΑΣ ΓΙΑ SL-L60	4
93-038	ΣΦΗΝΑ 12x8x27	2



screw



V: προχάραξη / spur



screw for spur



wedge



σφήνα



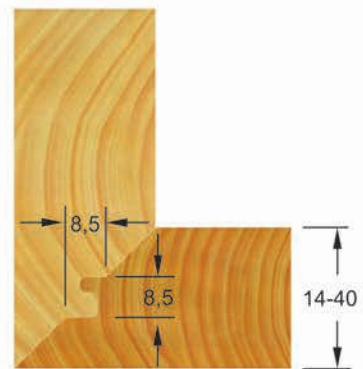
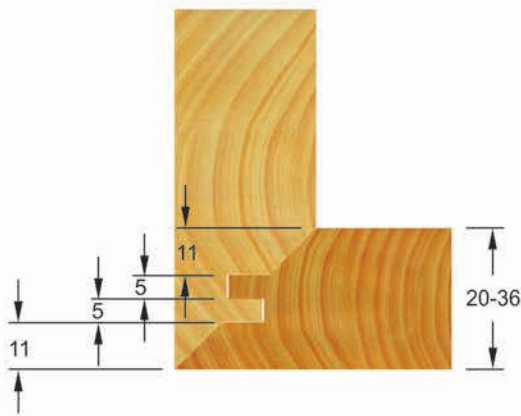
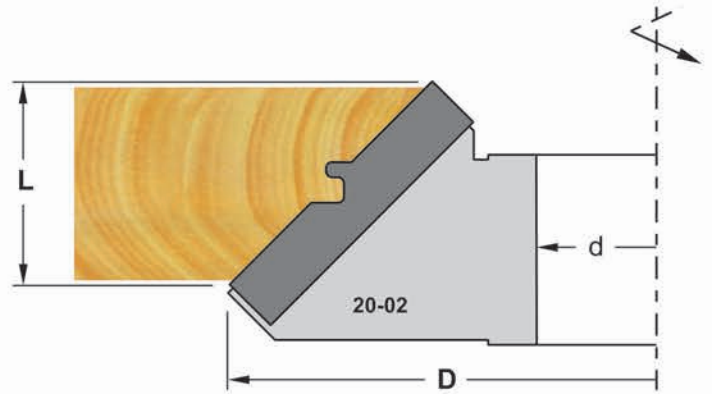
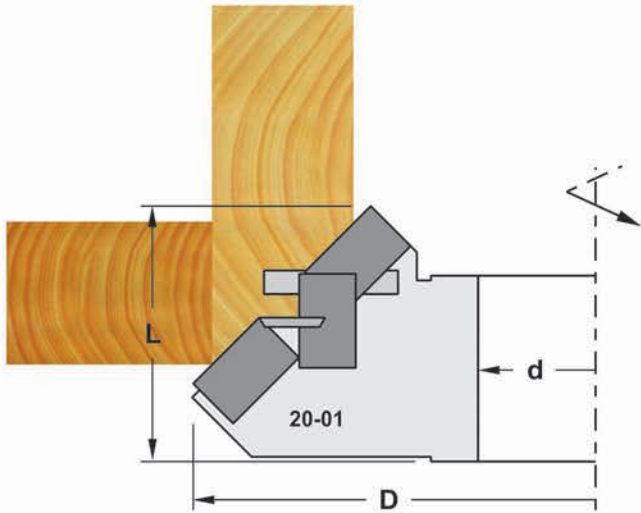

Part No	D	L	d	Z	V	I
20-01-17154	171	54	50	2+2	2	2
20-02-17842	178	42	50	3	---	---

η τιμή της φρέζας δεν περιλαμβάνει τα λάστιχα /  
grooving knives have extra price

Part No	ΠΕΡΙΓΡΑΦΗ / description	ΤΕΜ / pcs
SL-L20	20x12x1.5	6
63-0684	60x16x1.5	3
94-01-007	ΒΙΔΑ ΚΩΝΙΚΗ M6 L12	6
SL-L142	ΠΡΟΧΑΡΑΞΗ 14x14x2.0	2
94-09-001	ΒΙΔΑ ΓΙΑ ΠΡΟΧΑΡΑΞΗ M5 L8	2
SL-FKB4R SL-FKB5R	ΛΑΣΤΙΧΟ 34x16x4.0 ΛΑΣΤΙΧΟ 34x16x5.0	2 2
94-09-001	ΒΙΔΑ ΓΙΑ ΛΑΣΤΙΧΟ M5 L8	2
93-001	ΣΦΥΚΤΗΡΑΣ ΓΙΑ SL-L20	6

SS 21-02

SS 21-03

SS 35-24

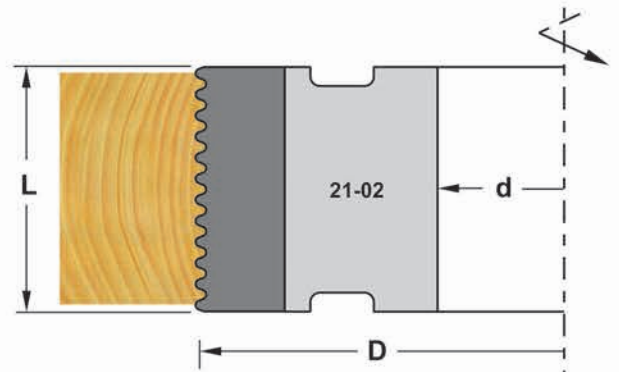
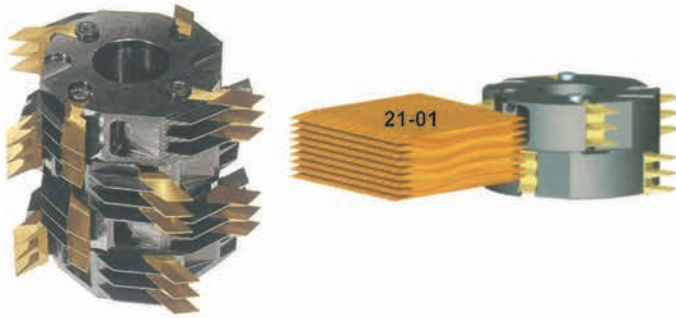

21-02



21-03

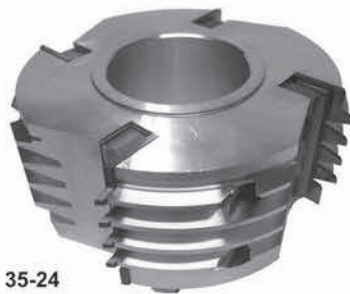
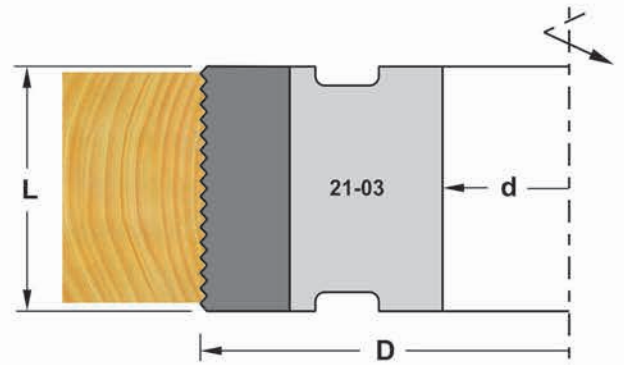

35-24

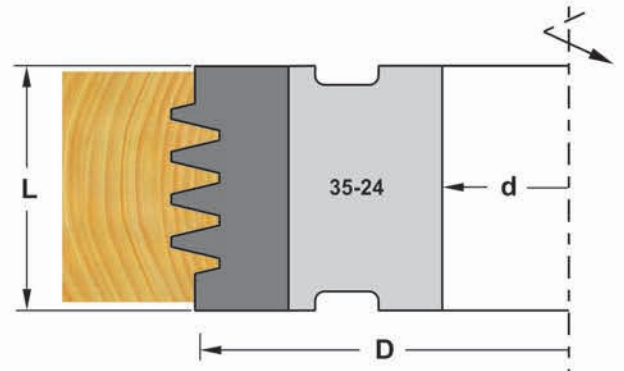

Part No	D	L	d	Z
21-01-12930	129 (160)	30.4	50	4
21-02-12640	126	40.4	50	4
21-02-12660	126	60.4	50	4
21-02-12550	125	50	50	4
21-02-12560	125	60	50	4
21-03-12580	125	80	50	4
35-24	120	50.3	50	4

η τιμή της φρέζας SS 21-01 δεν περιλαμβάνει τα χτένια / knives have extra price only for SS 21-01



για SS 21-02 / for SS 21-02



για SS 21-03 / for SS 21-03



για SS 35-24 / for SS 35-24



screw

Part No	ΠΕΡΙΓΡΑΦΗ / description	TEM / pcs
50-CGMZ0S33	28.4x38.5x14 10/11	4
63-0818	60x12x1.5	4
63-0818-1	50x12x1.5	4
63-1754	40.4x12.5x1.5	4
63-1755	60.4x12.5x1.5	4
63-0977	80x14x2.0	4
62-0770	50.3x22.9x2.0	4
94-02-003	ΒΙΔΑ ΠΙΕΣΕΩΣ M8 L16	8 12(21-03)



Lmax (0°) =48	Lmax (35°)=39
Lmax (5°) =48	Lmax (45°)=33
Lmax (10°)=47	Lmax (50°)=30
Lmax (15°)=46	Lmax (55°)=26
Lmax (20°)=45	Lmax (60°)=23
Lmax (25°)=43	Lmax (65°)=19
Lmax (30°)=41	Lmax (70°)=15

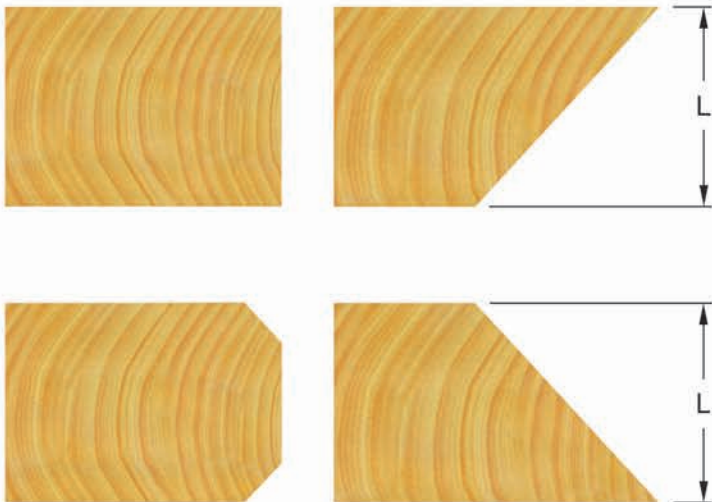
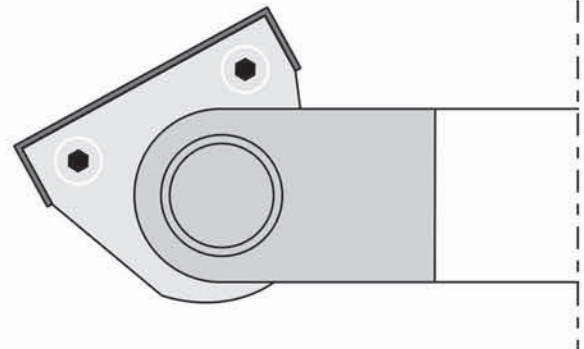
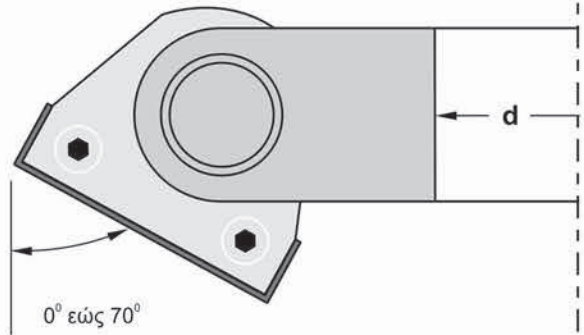
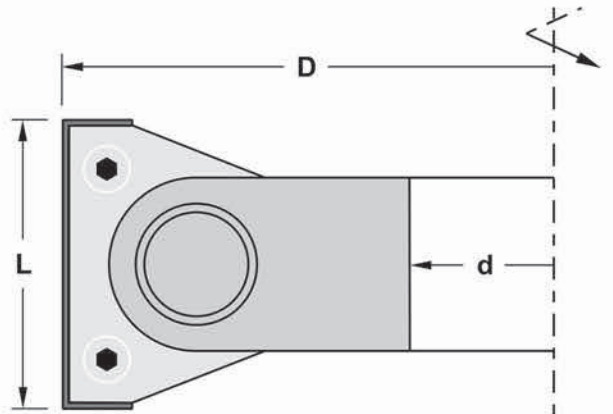

Part No	D	L	d	Z
22-01-17050	170	50	50	2



screw



wedge

Part No	ΠΕΡΙΓΡΑΦΗ / description	TEM / pcs
SL-L50	50x12x1.5	2
94-02-001	ΒΙΔΑ ΠΙΕΣΕΩΣ M6 L12	4



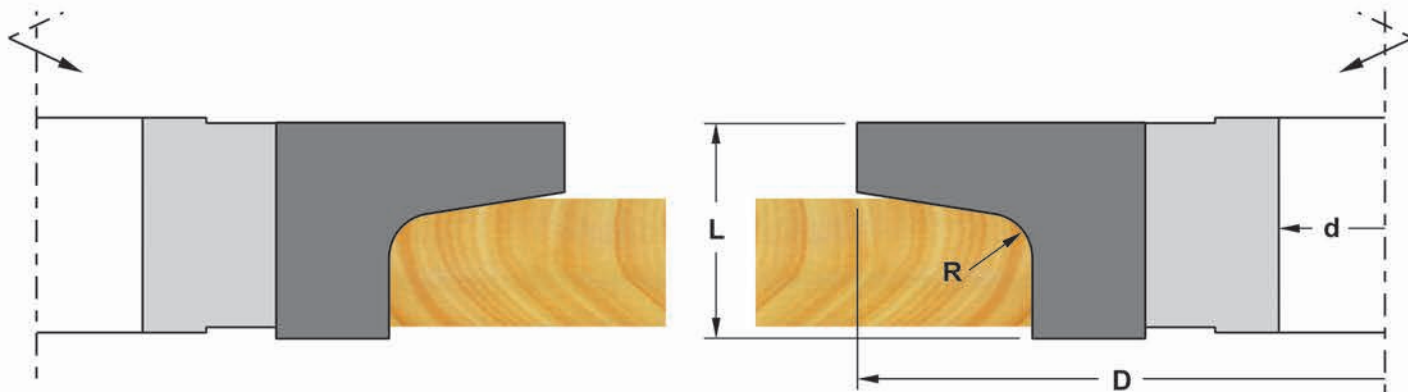

Part No	D	L	d	Z	R
25-01R	150	30	30	4	6
25-01L	150	30	30	4	6

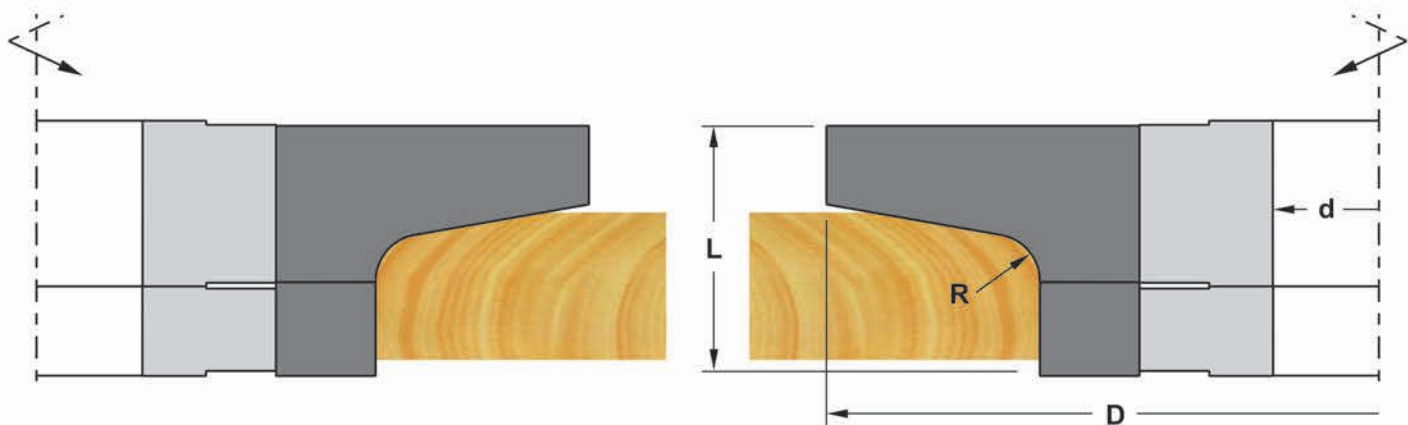

Part No	D	L	d	Z
26-01R	208/155	20/10	40	4
26-01	208/155	20/10	40	4

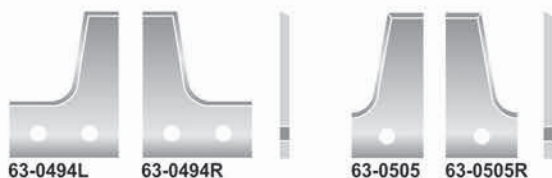

screw



wedge

Part No	ΠΕΡΙΓΡΑΦΗ / description	TEM / pcs
63-0494R/L (SS 25-01)	30x40x2 - R6	4
63-0505/R (SS 26-01)	20x40x2 - R6	4
SL-L12	12x12x1.5	4
94-01-007 (63-0494R/L)	ΒΙΔΑ ΚΩΝΙΚΗ M6 L12	8
94-01-009 (63-0505/R)	ΒΙΔΑ ΚΩΝΙΚΗ M6 L16	4
94-01-003 (SL-L12)	ΒΙΔΑ ΚΩΝΙΚΗ M4 L14	4



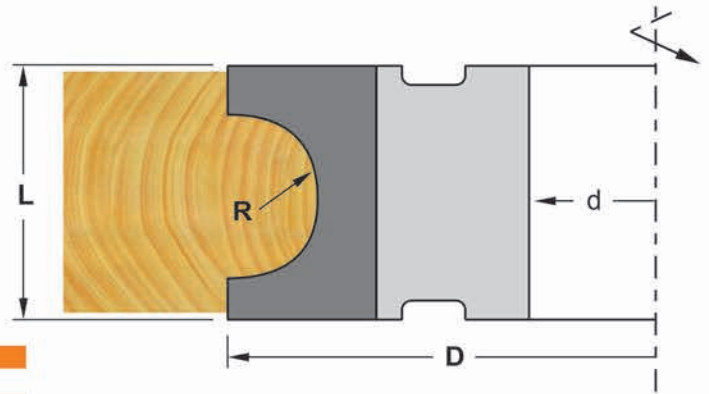

Part No	D	L	d	Z	R
32-01	165	60	50	4	20

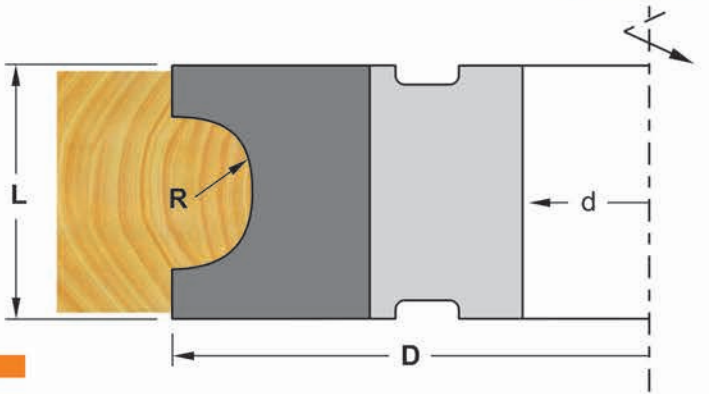

Part No	D	L	d	Z	R
32-02	163	30	50	4	15

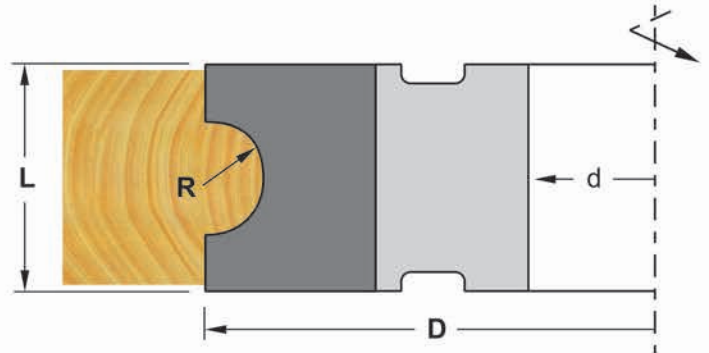

Part No	D	L	d	Z	R
32-03	147	40	50	4	10



63-0642

63-0670

63-0671



screw



screw



wedge

Part No	ΠΕΡΙΓΡΑΦΗ / description	TEM / pcs
63-0642 (SS 32-01)	60x35x2.0 - R20	4
63-0670 (SS 32-02)	50x39x2.0 - R15	4
63-0671 (SS 32-03)	40x30x2.0 - R10	4
94-01-007 (63-0671)	ΒΙΔΑ ΚΩΝΙΚΗ M6 L12	8
94-02-10 (63-0642, 63-0670)	ΒΙΔΑ ΠΙΕΣΕΩΣ M4 L16	12

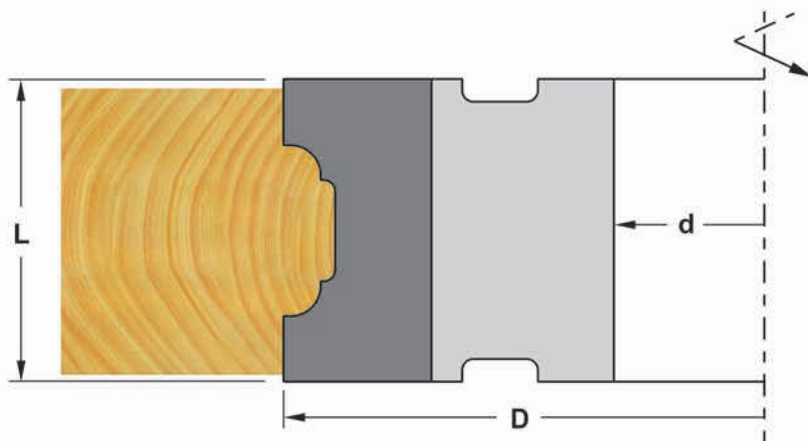

Part No	D	L	d	Z
33-01	147	40	40	4

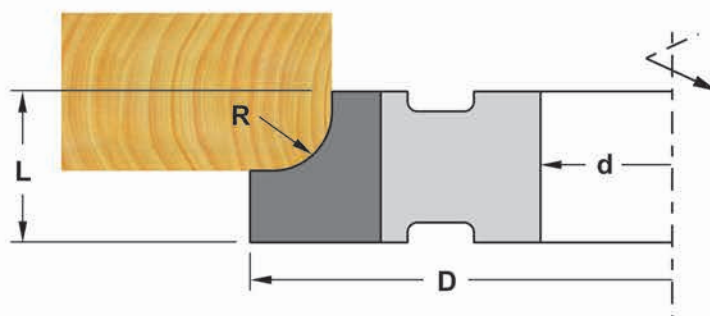
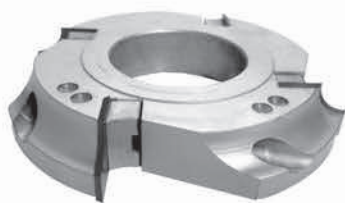

Part No	D	L	d	Z	R
34-01-12508	125	20	50	4	8
34-01-12510	125	20	50	4	10



63-0654



63-0685 / 63-0686



screw



screw



wedge

Part No	ΠΕΡΙΓΡΑΦΗ / description	TEM / pcs
63-0654 (SS 33-01)	40x29.5x2.0	4
63-0685 (SS 34-01 R8)	20x25.4x2.0 - R8	4
63-0686 (SS 34-01 R10)	20x25.4x2.0 - R10	4
94-02-10 (63-0685, 63-0686)	ΒΙΔΑ ΠΙΕΣΕΩΣ M4 L16	4
94-01-007 (63-0654)	ΒΙΔΑ ΚΩΝΙΚΗ M6 L12	8

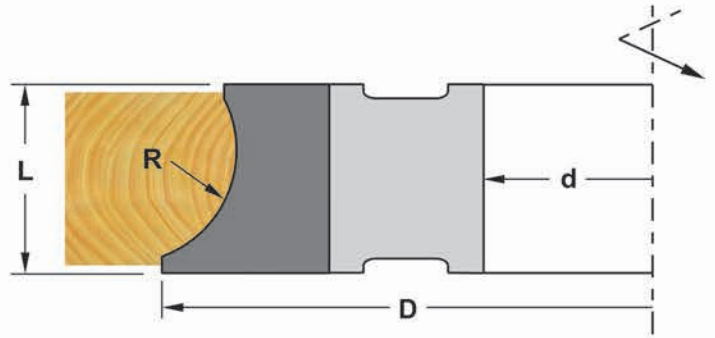
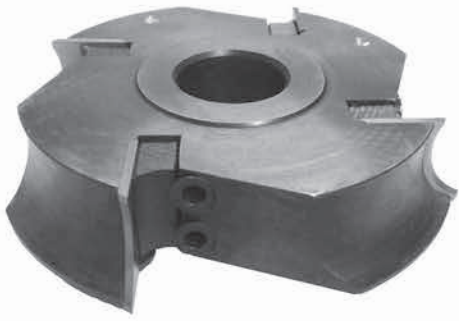

Part No	D	L	d	Z	R
37-01	130	25	30	4	15

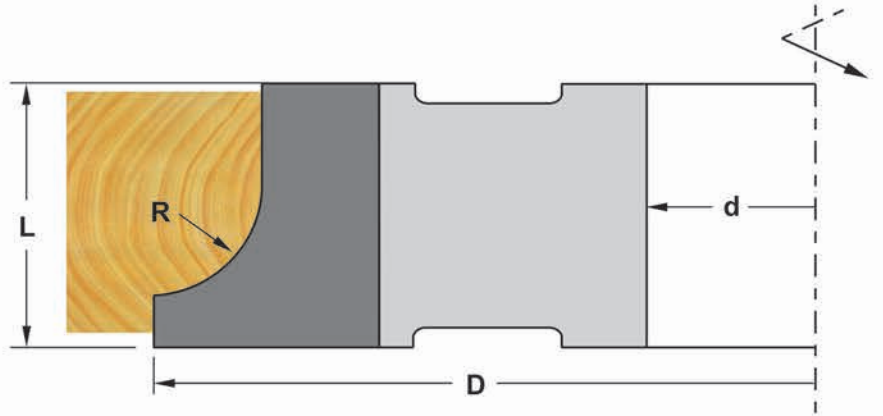
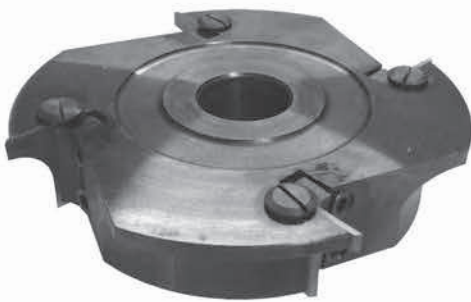

Part No	D	L	d	Z	R
38-01R	170	35	35	4	15
38-01L	170	35	35	4	15



Part No	ΠΕΡΙΓΡΑΦΗ / description	TEM / pcs
63-0727 (SS 37-01)	25x30x2.0	4
63-0728R/L (SS 38-01)	35x30x2.0	4
94-01-007 (63-0727)	ΒΙΔΑ ΚΩΝΙΚΗ M6 L12 ΒΙΔΑ ΚΩΝΙΚΗ M5 L22	8 8



screw



wedge





ΤΥΠΟΣ Α / type A

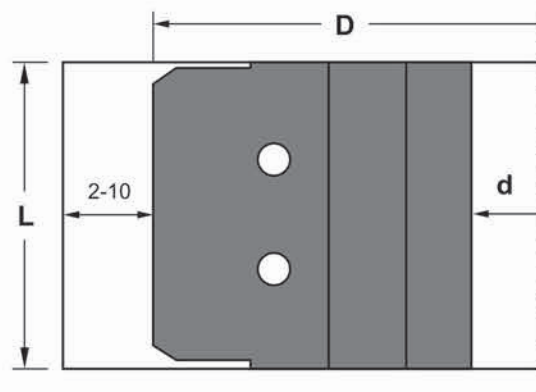

Part No	D	L	d	Z
50-01-3035A	116	30	35	3
50-01-3050A	116	30	50	3
50-01-4035A	116	40	35	3
50-01-4050A	116	40	50	3
50-01-5035A	116	50	35	3
50-01-5050A	116	50	50	3
50-01-6035A	116	60	35	3
50-01-6050A	116	60	50	3
50-01-8035A	116	80	35	3
50-01-8050A	116	80	50	3



ΤΥΠΟΣ Β / type B

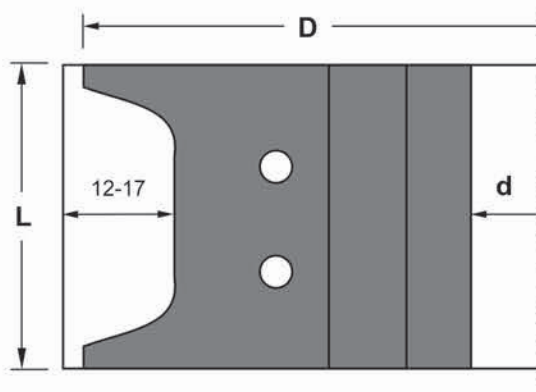

Part No	D	L	d	Z
50-01-4035B	137	40	35	3
50-01-4050B	137	40	50	3
50-01-5035B	137	50	35	3
50-01-5050B	137	50	50	3
50-01-6035B	137	60	35	3
50-01-6050B	137	60	50	3
50-01-8035B	137	80	35	3
50-01-8050B	137	80	50	3

Part No	ΠΕΡΙΓΡΑΦΗ / description	TEM / pcs
PL-830302Δ	30x30x3 ΔΙΑΜΟΡΦ.	3
PL-830352Δ	30x35x3 ΔΙΑΜΟΡΦ.	3
PL-840302Δ	40x30x3 ΔΙΑΜΟΡΦ.	3
PL-840352Δ	40x35x3 ΔΙΑΜΟΡΦ.	3
PL-840402Δ	40x40x3 ΔΙΑΜΟΡΦ.	3
PL-850302Δ	50x30x3 ΔΙΑΜΟΡΦ.	3
PL-850352Δ	50x35x3 ΔΙΑΜΟΡΦ.	3
PL-850402Δ	50x40x3 ΔΙΑΜΟΡΦ.	3
PL-860302Δ	60x30x3 ΔΙΑΜΟΡΦ.	3
PL-860352Δ	60x35x3 ΔΙΑΜΟΡΦ.	3
PL-860402Δ	60x40x3 ΔΙΑΜΟΡΦ.	3
PL-880302Δ	80x30x3 ΔΙΑΜΟΡΦ.	3
PL-880352Δ	80x35x3 ΔΙΑΜΟΡΦ.	3
PL-880402Δ	80x40x3 ΔΙΑΜΟΡΦ.	3

Part No	ΠΕΡΙΓΡΑΦΗ / description	TEM / pcs
PL-8305Δ	30x30-35-40x5 ΛΑΜΑΚΙΑ	3
PL-8405Δ	40x30-35-40x5 ΛΑΜΑΚΙΑ	3
PL-8505Δ	50x30-35-40x5 ΛΑΜΑΚΙΑ	3
PL-8605Δ	60x30-35-40x5 ΛΑΜΑΚΙΑ	3
PL-8805Δ	80x30-35-40x5 ΛΑΜΑΚΙΑ	3

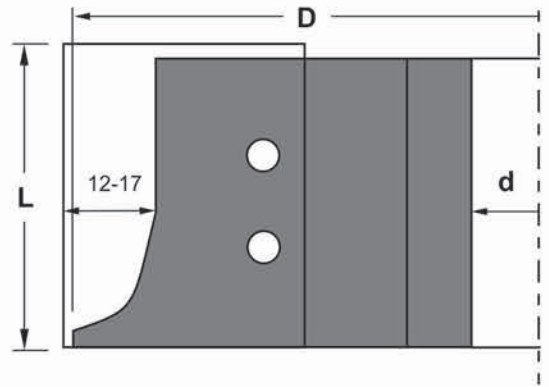

**ΤΥΠΟΣ C / type C**

Part No	D	L	d	Z
50-01-3035C	137	30	35	3
50-01-3050C	137	30	50	3
50-01-4035C	137	40	35	3
50-01-4050C	137	40	50	3
50-01-5035C	137	50	35	3
50-01-5050C	137	50	50	3
50-01-6035C	137	60	35	3
50-01-6050C	137	60	50	3

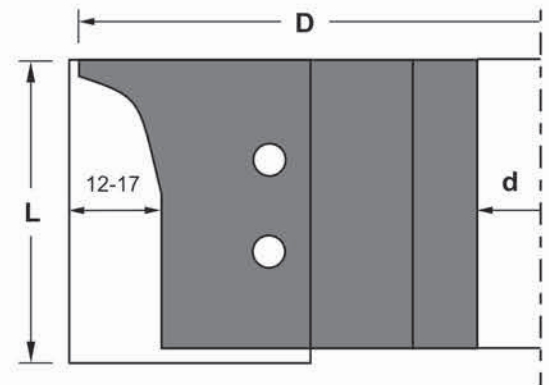
**ΤΥΠΟΣ D / type D**

Part No	D	L	d	Z
50-01-3035D	137	30	35	3
50-01-3050D	137	30	50	3
50-01-4035D	137	40	35	3
50-01-4050D	137	40	50	3
50-01-5035D	137	50	35	3
50-01-5050D	137	50	50	3
50-01-6035D	137	60	35	3
50-01-6050D	137	60	50	3

Part No	ΠΕΡΙΓΡΑΦΗ / description	TEM / pcs
PL-830303Δ	30x30x3 ΔΙΑΜΟΡΦ.	3
PL-830353Δ	30x35x3 ΔΙΑΜΟΡΦ.	3
PL-840303Δ	40x30x3 ΔΙΑΜΟΡΦ.	3
PL-840353Δ	40x35x3 ΔΙΑΜΟΡΦ.	3
PL-840403Δ	40x40x3 ΔΙΑΜΟΡΦ.	3
PL-850303Δ	50x30x3 ΔΙΑΜΟΡΦ.	3
PL-850353Δ	50x35x3 ΔΙΑΜΟΡΦ.	3
PL-850403Δ	50x40x3 ΔΙΑΜΟΡΦ.	3
PL-860303Δ	60x30x3 ΔΙΑΜΟΡΦ.	3
PL-860353Δ	60x35x3 ΔΙΑΜΟΡΦ.	3
PL-860403Δ	60x40x3 ΔΙΑΜΟΡΦ.	3
PL-880303Δ	80x30x3 ΔΙΑΜΟΡΦ.	3
PL-880353Δ	80x35x3 ΔΙΑΜΟΡΦ.	3
PL-880403Δ	80x40x3 ΔΙΑΜΟΡΦ.	3

Part No	ΠΕΡΙΓΡΑΦΗ / description	TEM / pcs
PL-8305Δ	30x30-35-40x5 ΛΑΜΑΚΙΑ	3
PL-8405Δ	40x30-35-40x5 ΛΑΜΑΚΙΑ	3
PL-8505Δ	50x30-35-40x5 ΛΑΜΑΚΙΑ	3
PL-8605Δ	60x30-35-40x5 ΛΑΜΑΚΙΑ	3

	Part No	L x W x T	ΤΥΠΟΣ ΜΗΧΑΝΗΣ / machine type
	63-0276 63-0277	20x16.7x2.0 R3 20x16.7x2.0 R3	
	63-0577R 63-0577L 63-0734R 63-0734L 63-0542R 63-0542L	14.5x14.5x2.0 R2.5 14.5x14.5x2.0 R2.5 14.5x14.5x2.0 R2 14.5x14.5x2.0 R2 14.5x14.5x2.0 R3 14.5x14.5x2.0 R3	
	SL-L14.5PR SL-L14.5PL SL-L14.5PR2.5 SL-L14.5PL2.5 SL-L14.5PR2 SL-L14.5PL2 SL-L15R2 SL-L15L2 SL-L15R2.5 SL-L15L2.5 SL-L15R3 SL-L15L3	12x14.5x2.0 R3 12x14.5x2.0 R3 12x14.5x2.0 R2.5 12x14.5x2.0 R2.5 12x14.5x2.0 R2 12x14.5x2.0 R2 15x14.5x2.0 R2 15x14.5x2.0 R2 15x14.5x2.0 R2.5 15x14.5x2.0 R2.5 15x14.5x2.0 R3 15x14.5x2.0 R3	HOLZHER HOLZHER HOLZHER HOLZHER HOLZHER HOLZHER HOLZHER HOLZHER HOLZHER HOLZHER HOLZHER HOLZHER
	63-0248 63-0249 63-0160 63-0161	20x15.8x2.0 R3 20x15.8x2.0 R3 20x15.8x2.0 R2 20x15.8x2.0 R2	CEHISA CEHISA CEHISA CEHISA
	63-0597R 63-0597L 63-0575R 63-0575L	10x20x2.0 R2 10x20x2.0 R2 10x20x2.0 R3 10x20x2.0R3	
	63-0262R3R 63-0263R3L	15x14.5x2.0 R3 15x14.5x2.0 R3	BRANDT, EBM, REICH BRANDT, EBM, REICH
	63-0351 63-0352	16x16.8x2.0 R2 16x16.8x2.0 R2	CASADEI CASADEI
	63-0564R 63-0564L	20x16x2.0 R3 20x16x2.0 R3	IMA IMA
	63-0407 63-0408 63-0545R 63-0545L	15x12x1.5 R3 15x12x1.5 R3 15x12x1.5 R2 15x12x1.5 R2	TECNOMA TECNOMA TECNOMA TECNOMA
	63-0715R 63-0715L	16x17.5x2.0 R2 16x17.5x2.0 R2	FRAVOL FRAVOL

	Part No	L x W x T	ΤΥΠΟΣ ΜΗΧΑΝΗΣ / machine type
	63-0085 63-0086	16x17.5x2.0 R3 16x17.5x2.0 R3	CGA CGA
	SL-L17P1 SL-L17P SL-L17P2 63-0024 63-0167 SL-L15P 63-0169 63-0466 63-0409 63-0392	16x17.5x2.0 R3 16x17.5x2.0 R3 16x17.5x2.0 R3 16x17.5x2.0 R3 16x17.5x2.0 R2 16x14.7x1.5 R3 15x17.5x2.0 R3 15x17.5x2.0 R2 12x12x1.5 R3 12x12x1.5 R2	--- --- --- CEHISA CEHISA --- CGA, MANEA CGA, MANEA HOLZHER HOLZHER
	63-0817 63-0414R2	12x13x2.0 R2.5 16x17.5x2.0 R2	BRANDT SCM
	63-1101 63-0245	20x16.2x2.0 R2 20x16x2.0 R3	BIESSE BIESSE
	63-0186 63-0413	12.7x12.7x3.2 R3 12.7x12.7x3.2 R2	
	SL-L12R3	12x20x2.0 R3	HOMAG, REICH
	SL-L111	13x19.5x2.0	
	63-0395R 63-0395L	25x18.7x2.0 25x18.7x2.0	BIESSE BIESSE
	63-0976R 63-0976L	45.8x18x2.0 45.8x18x2.0	HOMAG HOMAG

	Part No	L x W x T
	SL-NF1420 SL-NF1425 SL-NF1430 SL-NF1820 SL-NF1837	14x14x2.0 14x14x2.5 14x14x3.0 18x18x2.0 18x18x3.7
	SL-L222	22x19x2.0
	SL-L14-14-2 SL-L16-16-3	14x14x2.0 16x16x3.0
	SL-L19.4-L SL-L19.5-R SL-L19.5-L	19.4x12x1.5 15° 19.5x12x1.5 10° 19.5x12x1.5 10°
	SL-L29.5-R SL-L29.5-L SL-L49.5-R SL-L49.5-L	29.5x12x1.5 29.5x12x1.5 49.5x12x1.5 49.5x12x1.5
	SL-L50 (357892) SL-L60 (2011894)	50x12x1.5 60x12x1.5
	SL-L50-3-4	50x12x1.5
	SL-L10.5-4 SL-L172 SL-L192	10.5x10.5x1.5 17x17x2.0 19x19x2.0
	SL-L7 SL-L9.6 SL-L10.5 SL-L11 SL-L11.6 SL-L12 SL-L13 SL-L15 SL-L17 SL-L18 SL-L19 SL-L20 SL-L24.7 SL-L30 SL-L40 SL-L50 SL-L60	7x12x1.5 9.6x12x1.5 10.5x12x1.5 11x12x1.5 11.6x12x1.5 12x12x1.5 13x12x1.5 15x12x1.5 17x12x1.5 18x12x1.5 19x12x1.5 20x12x1.5 24.7x12x1.5 30x12x1.5 40x12x1.5 50x12x1.5 60x12x1.5
	SL-L9 SL-L10-4 SL-L19.5 SL-L29.5-4 SL-L49.5-4 SL-L59.5  SL-L9-4 SL-L19.5-4 SL-L29.5-4 SL-L39.5-4 SL-L49.5-9	9x12x1.5 10x12x1.5 19.5x12x1.5 29.5x12x1.5 49.5x12x1.5 59.5x12x1.5  9x9x1.5 19.5x9x1.5 29.5x9x1.5 39.5x9x1.5 49.5x9x1.5



	Part No	L x W x T
	SL-L30MINI	30x5.5x1.1
	SL-L20MINI SL-L25MINI SL-L30MINI SL-L40MINI SL-L50MINI	20x5.5x1.1 25x5.5x1.1 30x5.5x1.1 40x5x5x1.1 50x5.5x1.1
	SL-KF75N SL-KF82N SL-KF92N SL-KF102N	75x5.5x1.1 82x5.5x1.1 92x5.5x1.2 102x5.5x1.2
	SL-L50-HE40 SL-L60-HE40	50x12x1.5 60x12x1.5
	SL-L34-16-4 SL-L34-16-5	34x16x4.0 34x16x5.0
	SL-AL75  ΒΑΣΕΙΣ ΓΙΑ ΠΛΑΝΑΚΙΑ  SL-AL82	AEG/BOSCH/MAFELL/HAFFNER/ HOLZ-HER/METABO/SKILL/ BLACK&DECKER/SCHEER  AEG/BOSCH/MAFELL/HAFFNER/ HOLZ-HER/METABO/SKILL/FEIN BLACK&DECKER/FELISATTI/ CASALS/PEUGEOT/RYOBI
	SL-AD82 SL-AD92  ΒΑΣΕΙΣ ΓΙΑ ΠΛΑΝΑΚΙΑ	MAKITA/HITACHI/RYOBI/ PENTAGON





HARTMETALL

**ΒΙΜΗΚΕ ΑΒΕΕ**

---

**ΚΑΤΑΣΚΕΥΗ & ΕΜΠΟΡΙΑ ΚΟΠΤΙΚΩΝ ΕΡΓΑΛΕΙΩΝ**  
ΕΔΡΑ/ΕΡΓΟΣΤΑΣΙΟ: ΚΡΥΣΤΑΛΛΗ 28, 12131 ΠΕΡΙΣΤΕΡΙ  
ΤΗΛ.: 210 5751920, 210 5751856 - FAX: 210 5762415  
[www.bimike.gr](http://www.bimike.gr) / [info@vimike.gr](mailto:info@vimike.gr)